

GPIB Command Syntax **for**

E1961A AMPS/136 Mobile Test Application Revision A.11.20

1000-1926
Print Date: July 2006

www.agilent.com/find/E1961A



Agilent Technologies

Contents

| | |
|--|----|
| GPIB Syntax for the E1961A | 5 |
| Diagram Conventions | 5 |
| Description | 5 |
| ABORt | 7 |
| AFGenerator | 8 |
| CALibration | 8 |
| CALCulate:SMONitor | 9 |
| CALL:ACC | 10 |
| CALL:AVCTest | 10 |
| CALL:CCHannel | 10 |
| CALL:CONNected | 10 |
| CALL:CONTRol:DOWNlink:FREQuency:AUTO | 11 |
| CALL:DCCH | 11 |
| CALL:DTC:BURSt | 11 |
| CALL:DTC:IBERror | 12 |
| CALL:END | 12 |
| CALL:FM | 12 |
| CALL:HANDoff | 13 |
| CALL:MCCode | 13 |
| CALL:MS | 13 |
| CALL:OPERating | 16 |
| CALL:ORIGinate | 16 |
| CALL:PAGing:PNUMBER | 16 |
| CALL:PAGing:REPeat | 16 |
| CALL:POWER | 17 |
| CALL:REGister | 17 |
| CALL:RFGenerator | 17 |
| CALL:SETup | 18 |
| CALL:SID | 20 |
| CALL:SOCode | 20 |
| CALL:STATus | 20 |
| CALL:TCHannel | 20 |
| FETCh:ACPower | 21 |
| FETCh:AFANalyzer | 22 |
| FETCh:ATXPower | 24 |
| FETCh:FM | 25 |
| FETCh:FSTability | 27 |
| FETCh:IQTuning | 28 |
| FETCh:LBERror | 28 |
| FETCh:MACCuracy | 29 |
| FETCh:SAUDio | 32 |
| FETCh:SMONitor | 33 |

Contents

| | |
|--|----|
| INITiate | 33 |
| READ | 35 |
| RFANalyzer | 36 |
| SETup[:ALL]:CONTinuous | 38 |
| SETup:ACPower | 38 |
| SETup:AFANalyzer | 39 |
| SETup:ATXPower | 40 |
| SETup:DPOWer | 41 |
| SETup:DTXPower | 42 |
| SETup:FM | 43 |
| SETup:FSTability | 45 |
| SETup:IQTuning | 46 |
| SETup:LBError | 48 |
| SETup:MACCuracy | 49 |
| SETup:SAUDio | 50 |
| SETup:SMONitor | 52 |
| STATus:OPERation | 54 |
| STATus:PRESet | 58 |
| STATus:QUEStionable | 59 |
| Status Byte Register | 65 |
| Standard Event Status Register | 66 |
| SYSTem:APPLication | 69 |
| SYSTem:BEEPer | 69 |
| SYSTem:CONFIgure:INFormation:HARDware:VERBose? | 69 |
| SYSTem:COMMunicate | 70 |
| SYSTem:CORRection | 71 |
| SYSTem:CURRent:TA | 71 |
| SYSTem:ERRor? | 72 |
| SYSTem:MEASurement:RESet | 72 |
| SYSTem:PRESet | 72 |
| SYSTem:ROSCillator | 72 |
| SYSTem:SYNChronized | 72 |
| IEEE 488.2 Common Commands | 72 |

GPIB Syntax for the E1961A

Diagram Conventions

Description

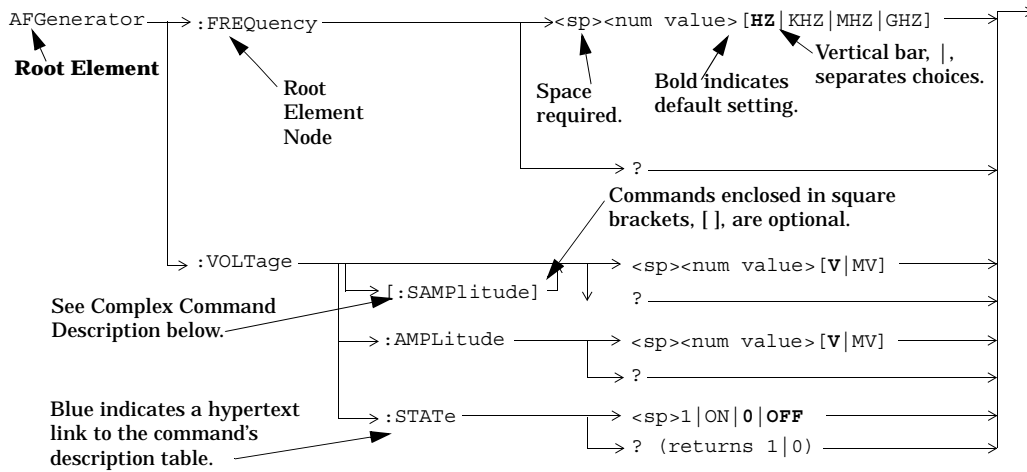

ABORt

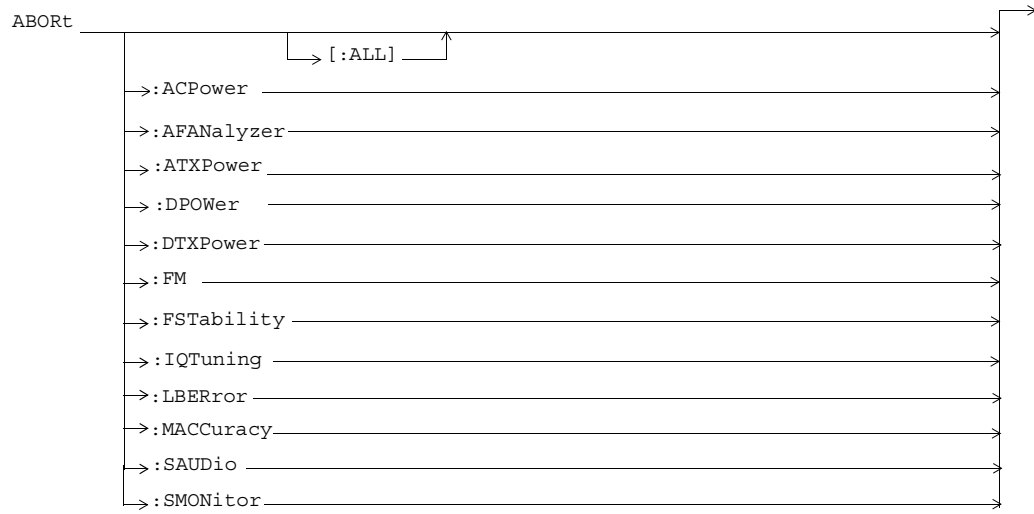

GPIB Syntax for the E1961A

AFGenerator

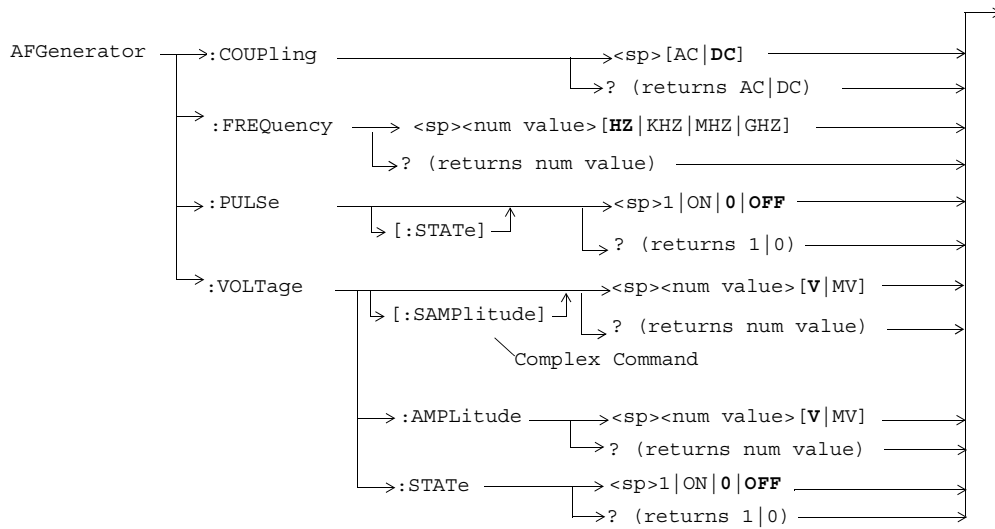

CALibration

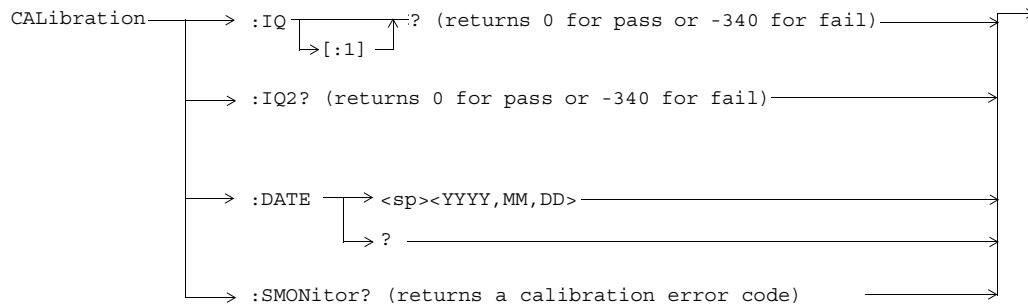

CALCulate:SMONitor

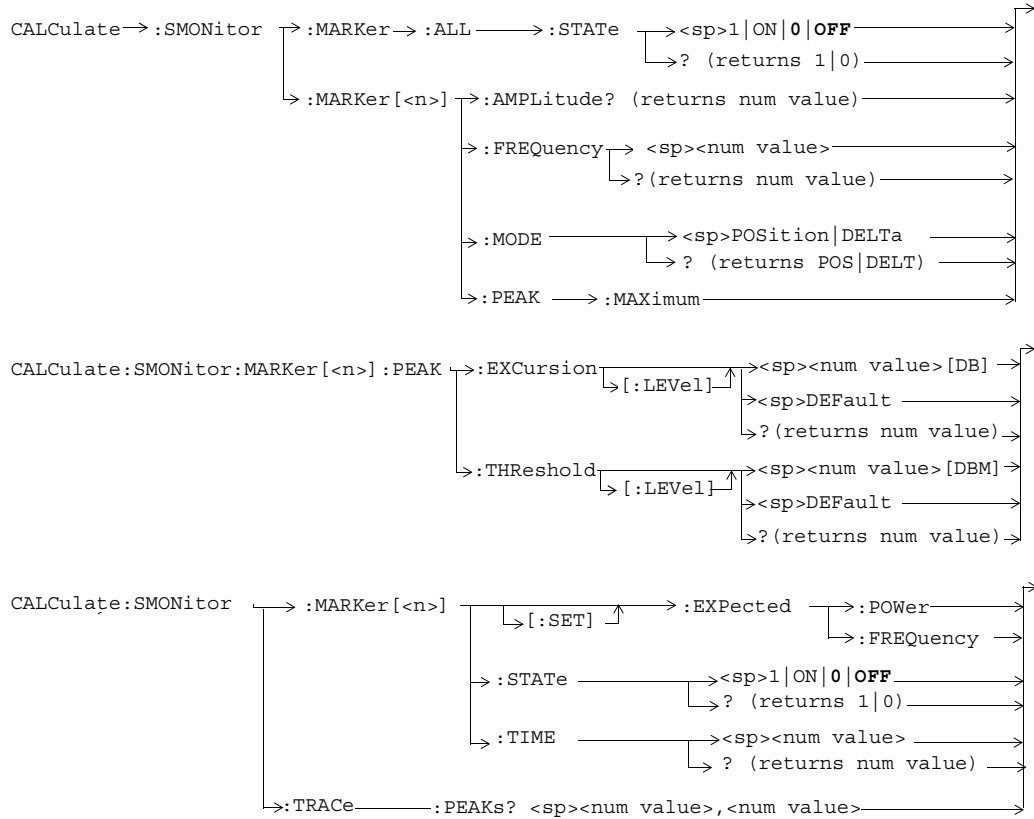

GPIO Syntax for the E1961A

CALL:ACC

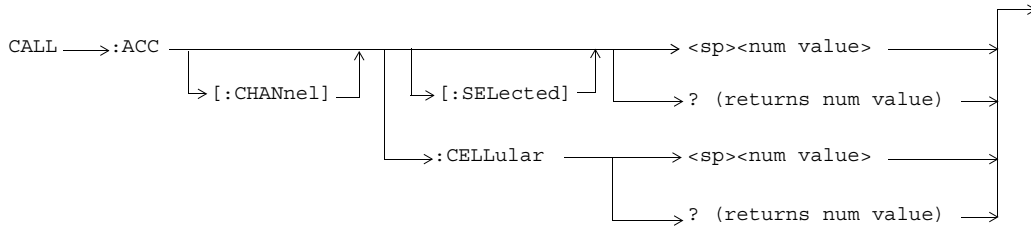

CALL:AVCTest

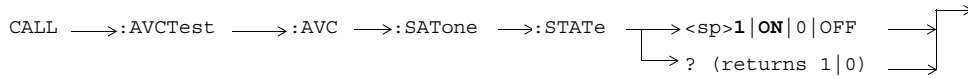

CALL:CCHannel

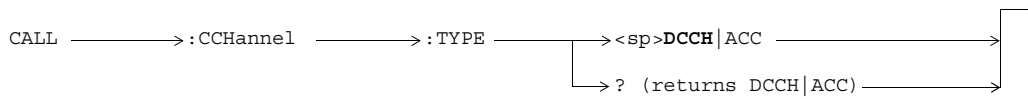

CALL:CONNECTed

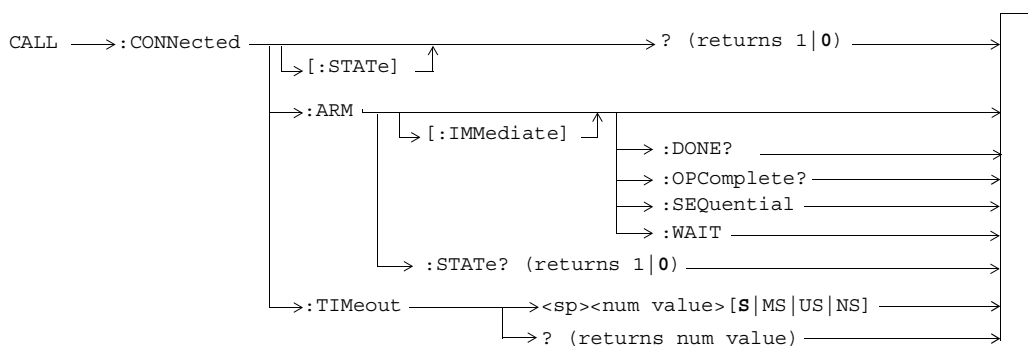

CALL:CONTROL:DOWNlink:FREQuency:AUTO

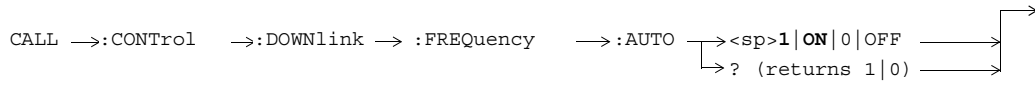

CALL:DCCH

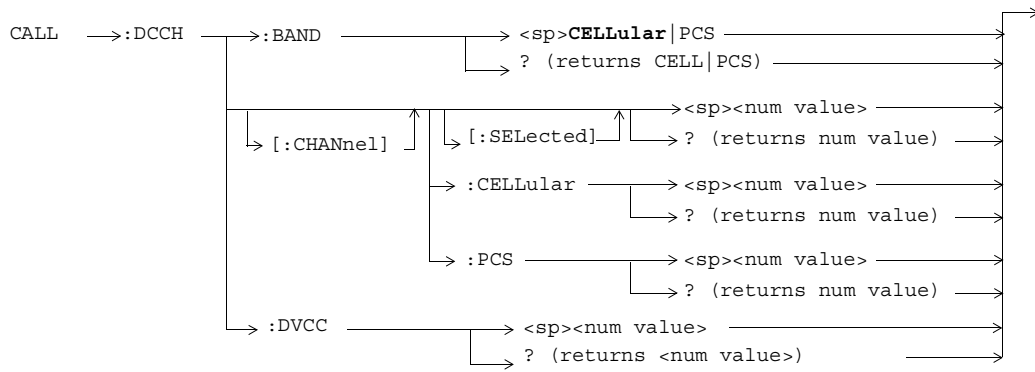

CALL:DTC:BURSt

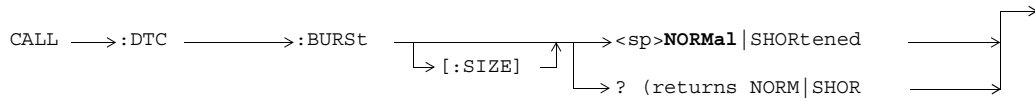

GPIB Syntax for the E1961A

CALL:DTC:IBERror

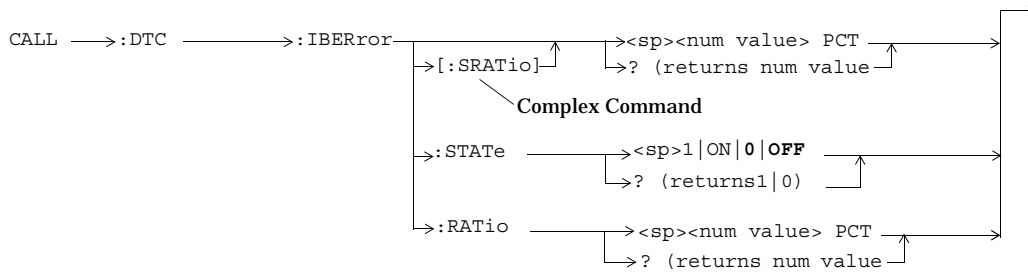

CALL:END

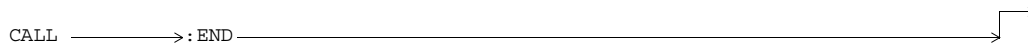

CALL:FM

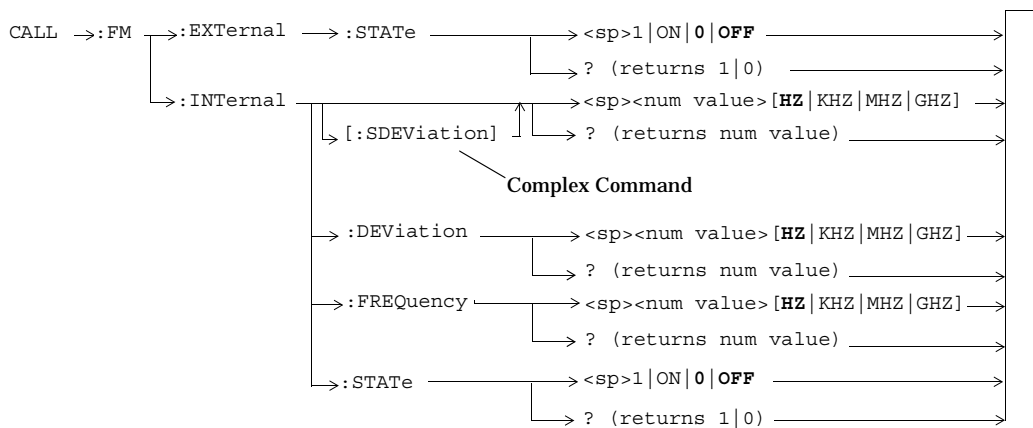

CALL:HANDoff

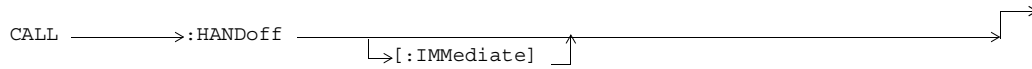

CALL:MCCode

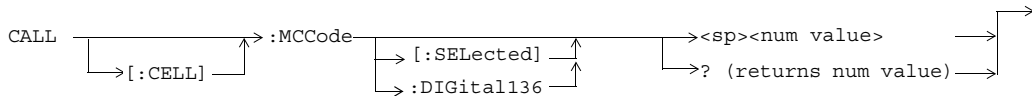

CALL:MS

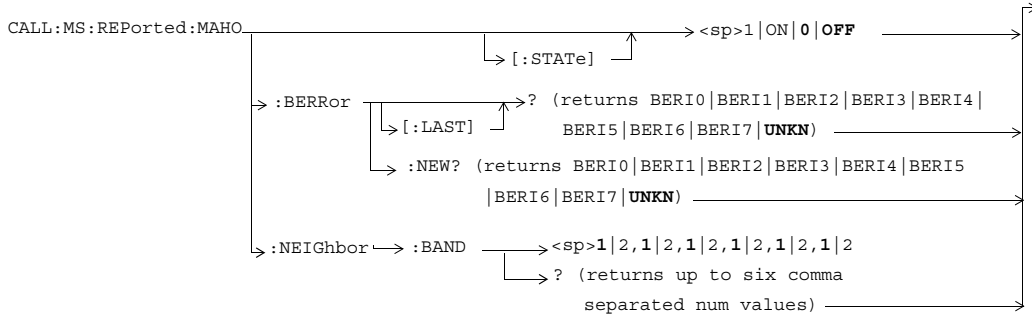
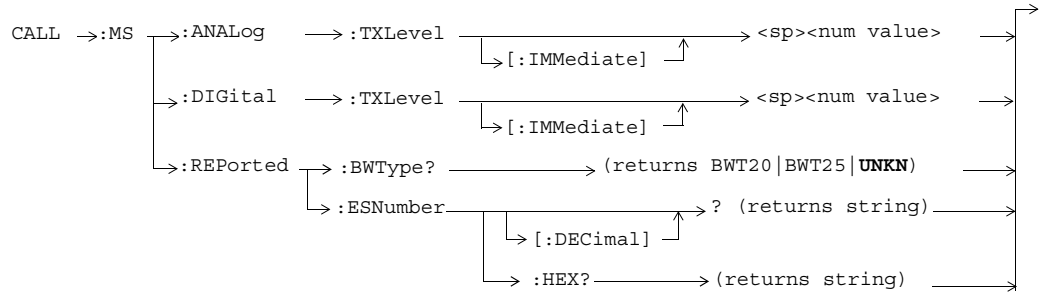

GPIB Syntax for the E1961A

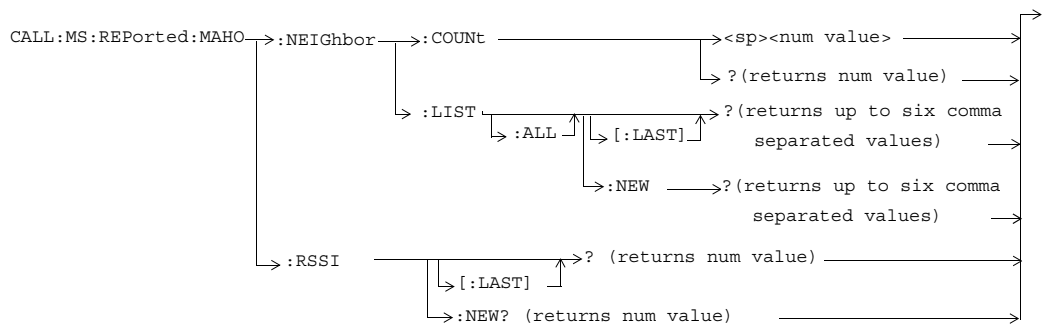
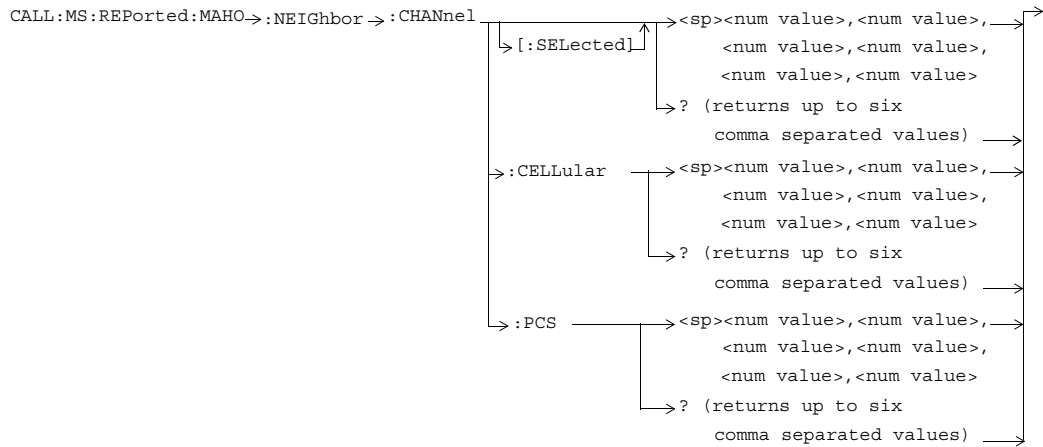

GPIB Syntax for the E1961A

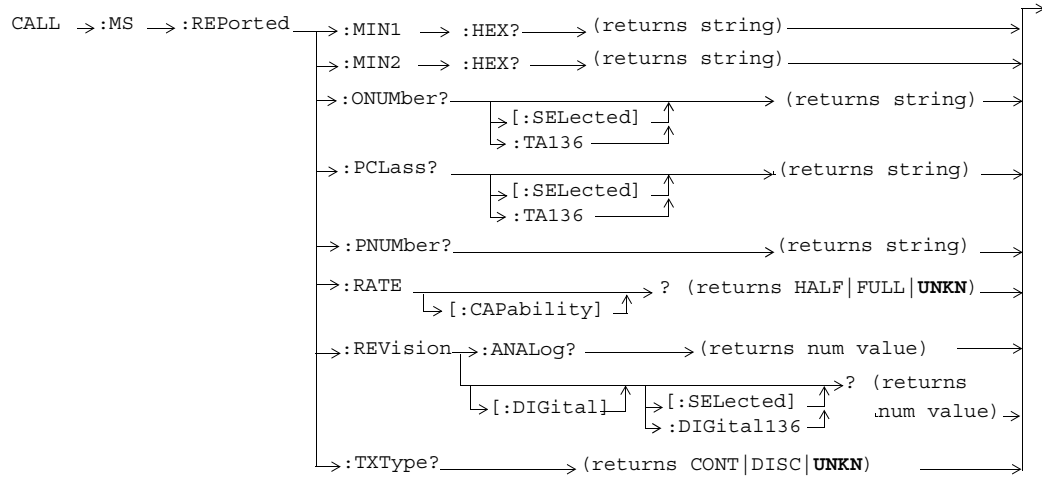

GPIB Syntax for the E1961A

CALL:OPERating

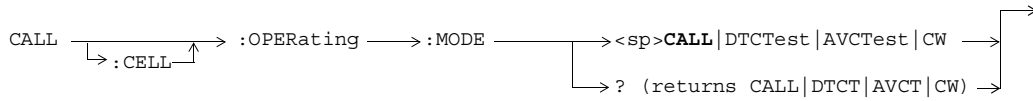

CALL:ORIGinate

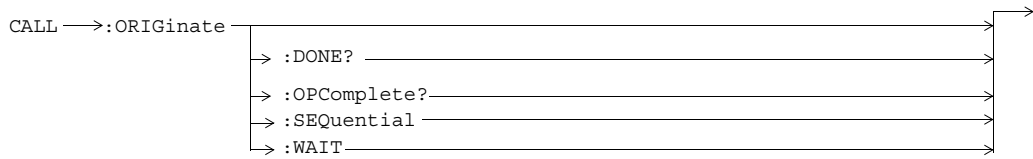

CALL:PAGing:PNUMBER



CALL:PAGing:REPeat

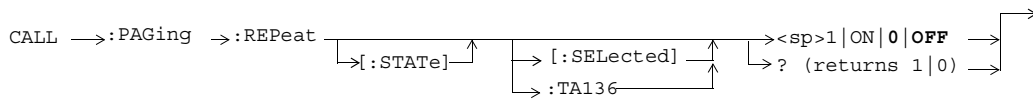

CALL:POWer

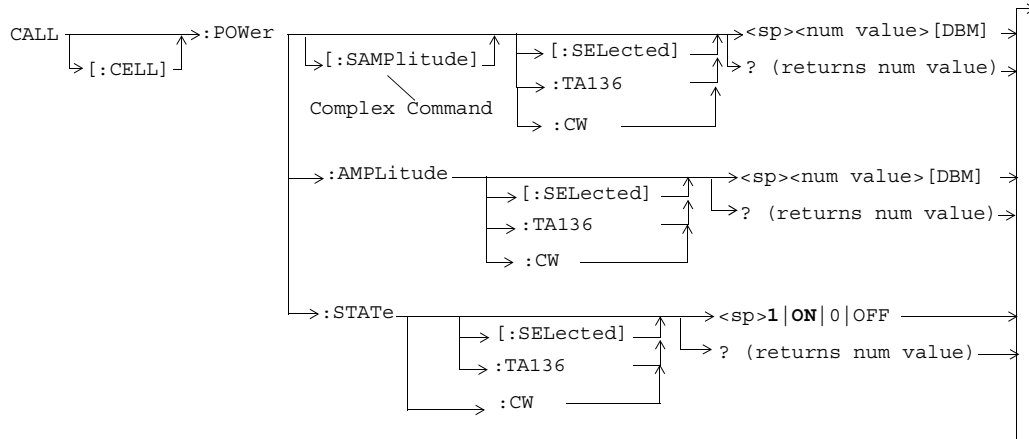

CALL:REGister

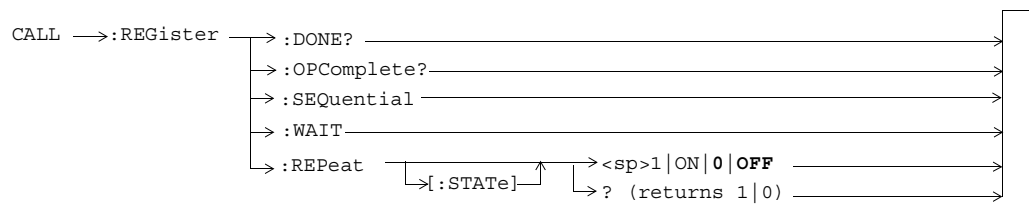

CALL:RFGenerator

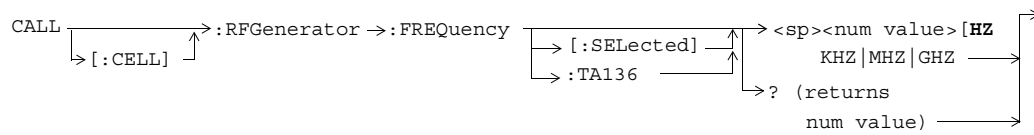

GPIB Syntax for the E1961A

CALL:SETup

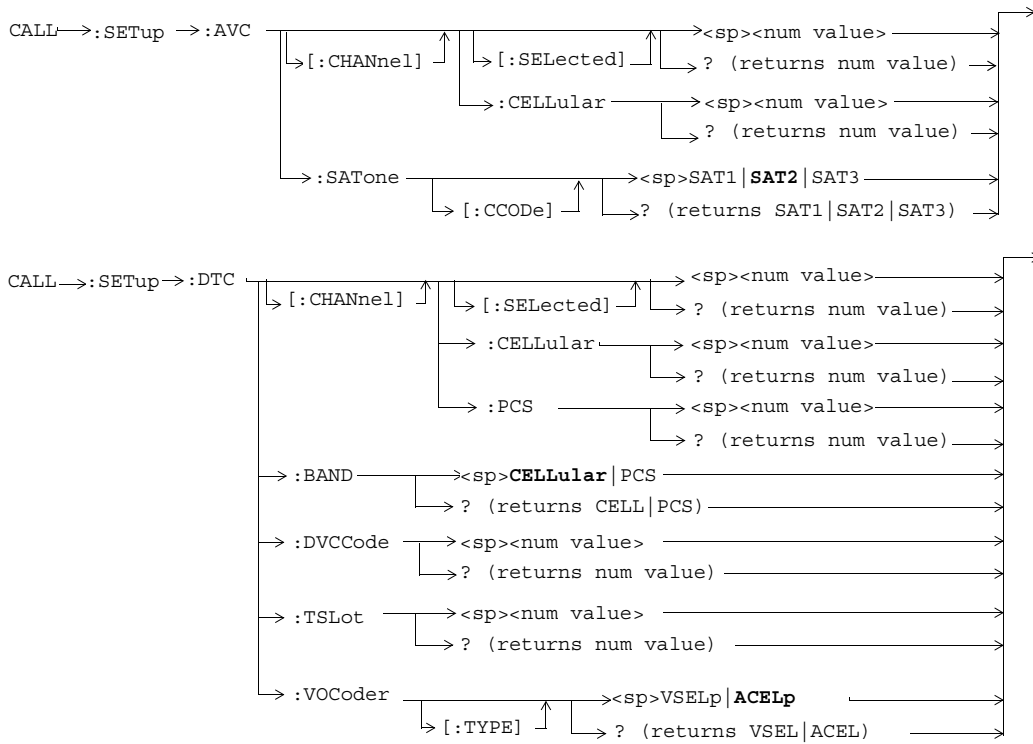

GPIB Syntax for the E1961A

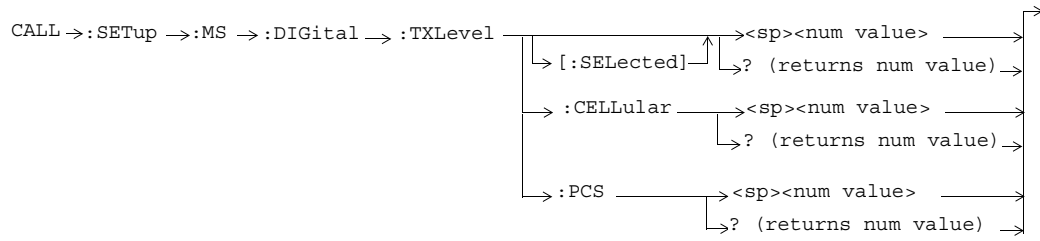
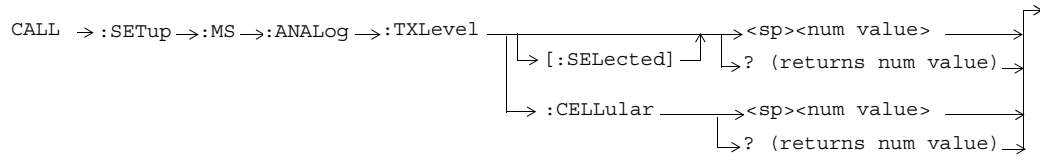

GPIB Syntax for the E1961A

CALL:SID

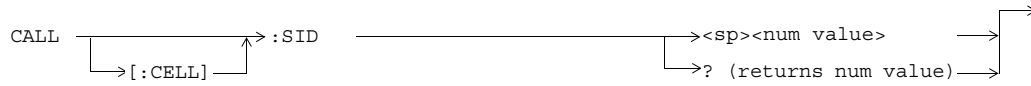

CALL:SOCode

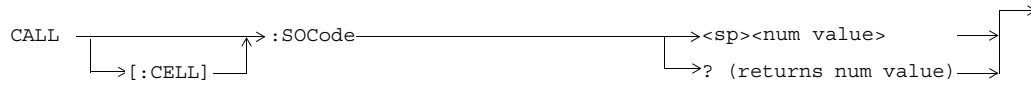

CALL:STATus

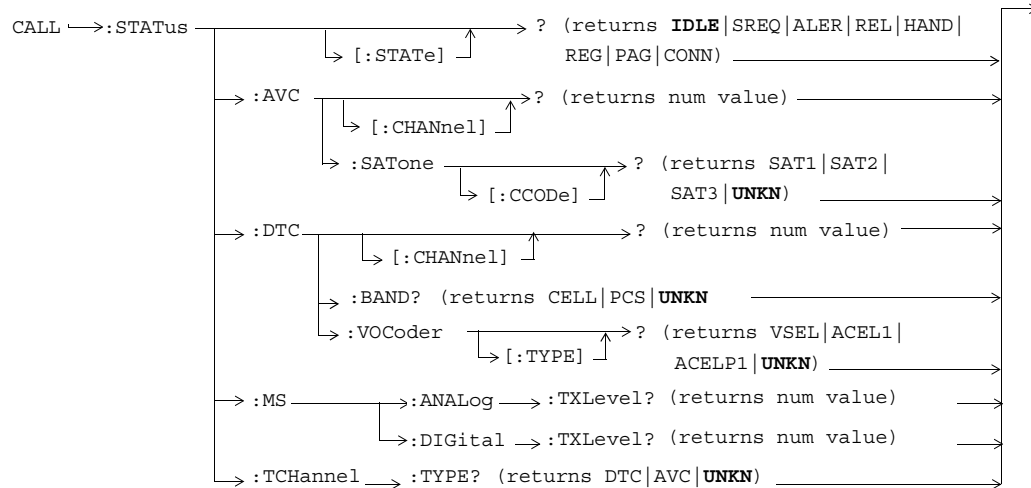

CALL:TCHannel



FETCh:ACPower

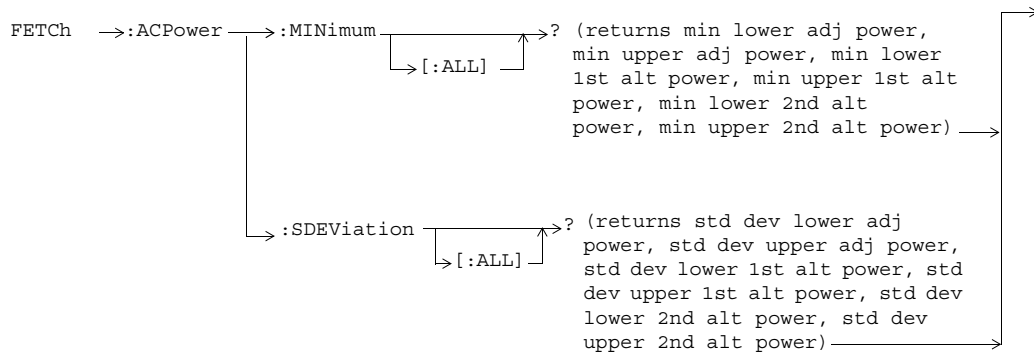
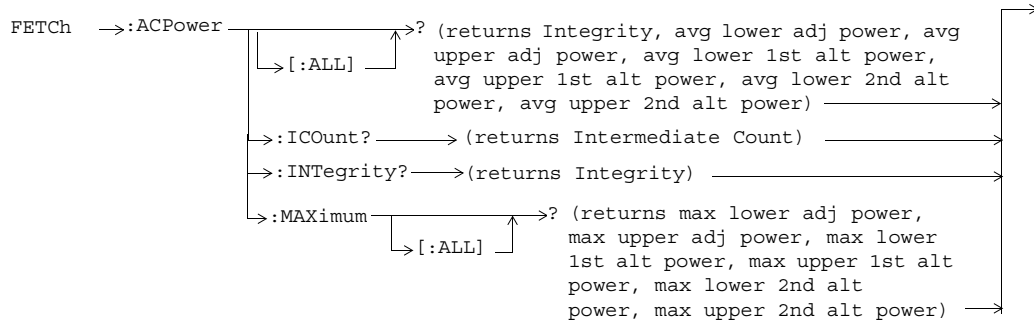

GPIB Syntax for the E1961A

FETCh:AFANalyzer

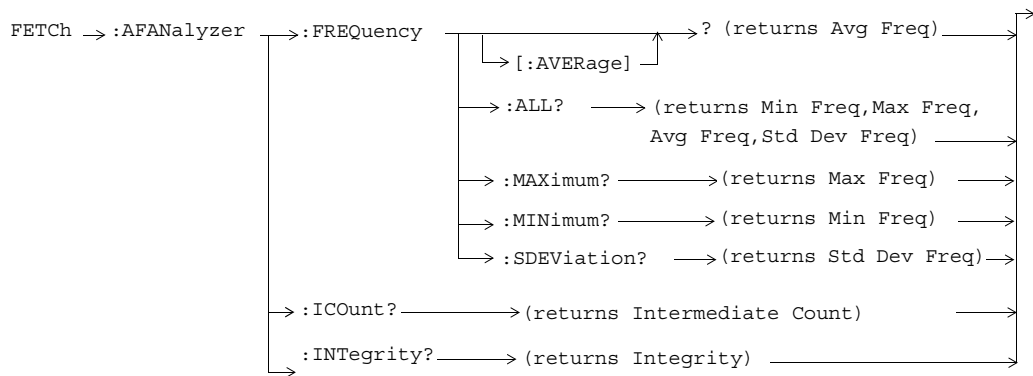
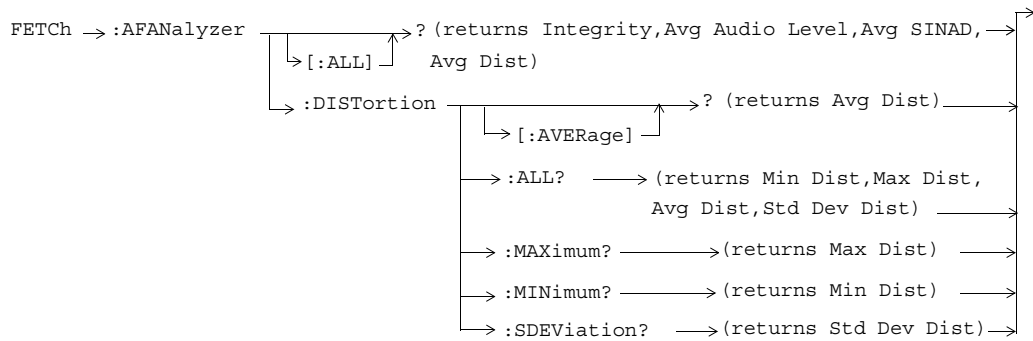

GPIB Syntax for the E1961A

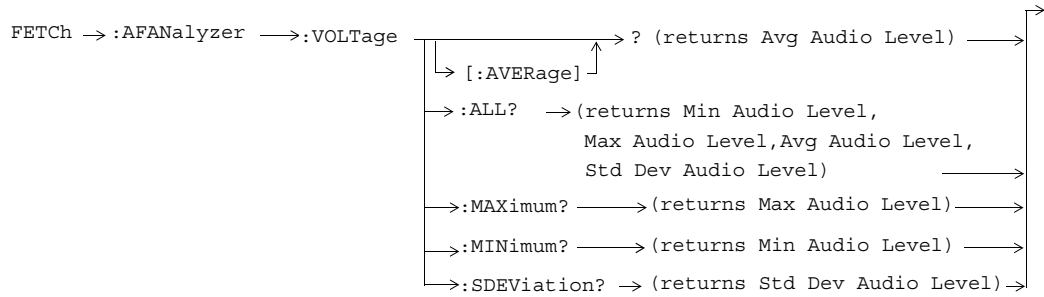
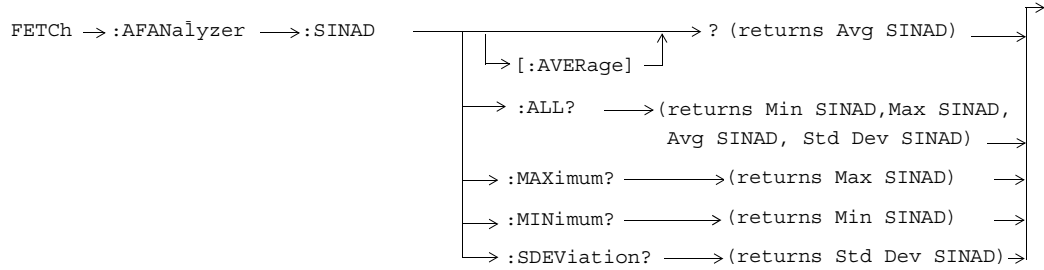

GPIB Syntax for the E1961A

FETCh:ATXPower

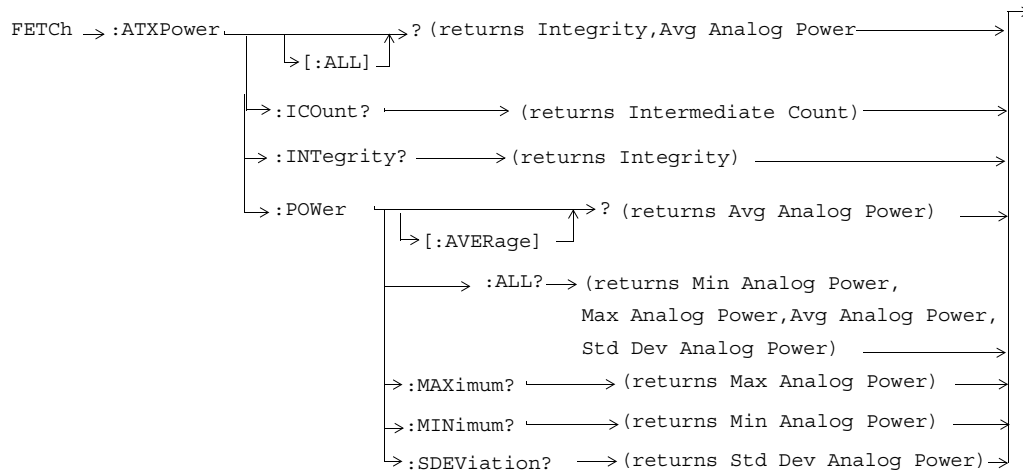

FEtCh:FM

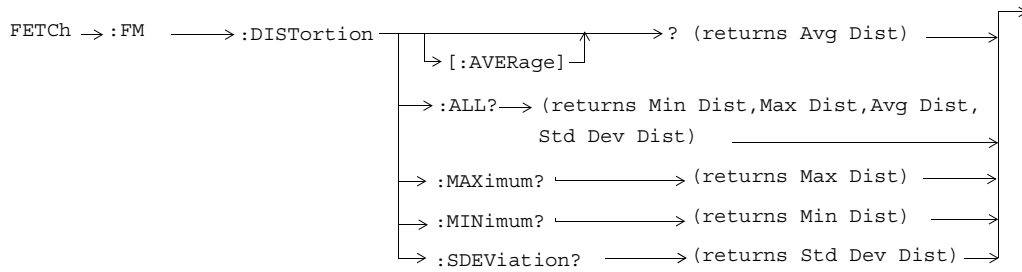
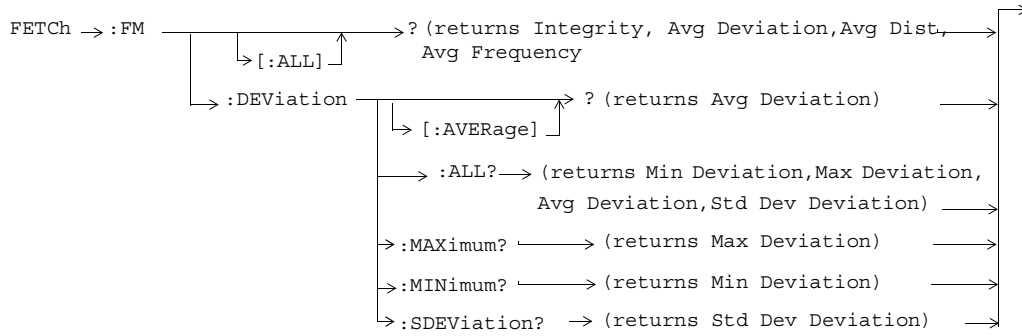

GPIB Syntax for the E1961A

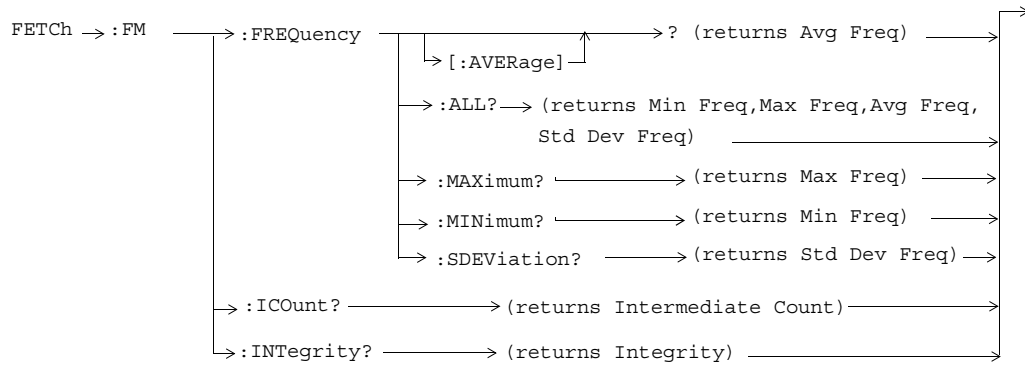

FEtCh:FStability

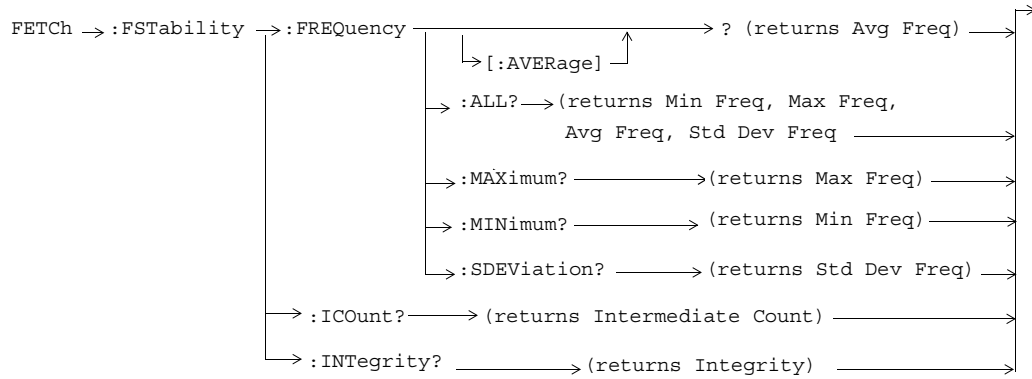
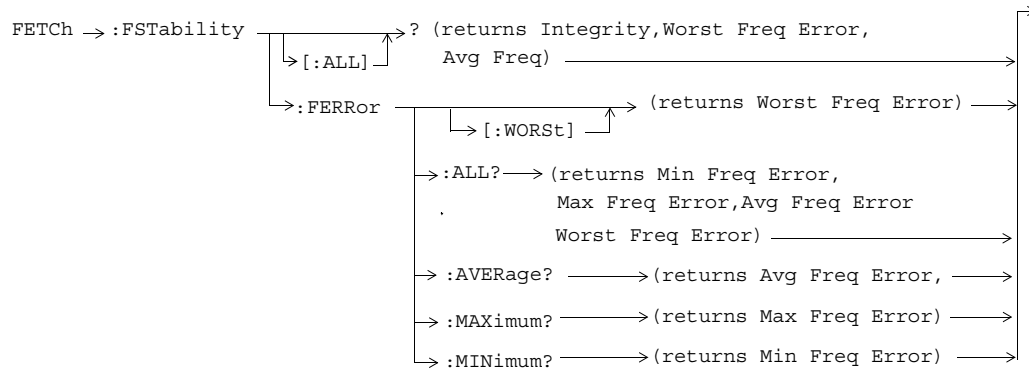

GPIB Syntax for the E1961A

FETCH:IQTuning

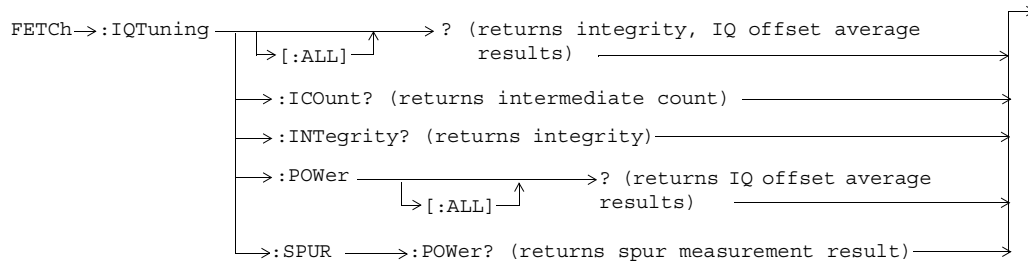

FETCH:LBError

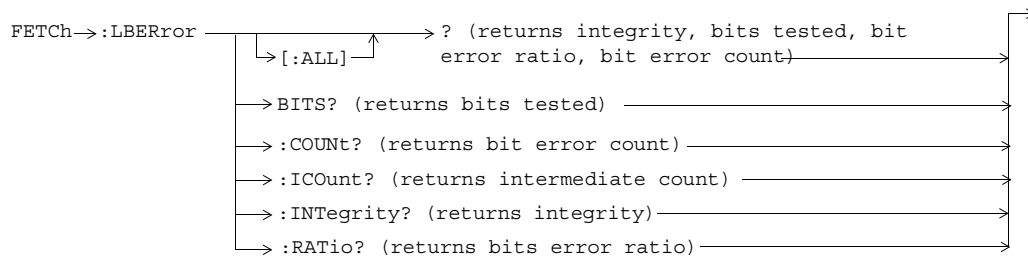

FEtCh:MAccuracy

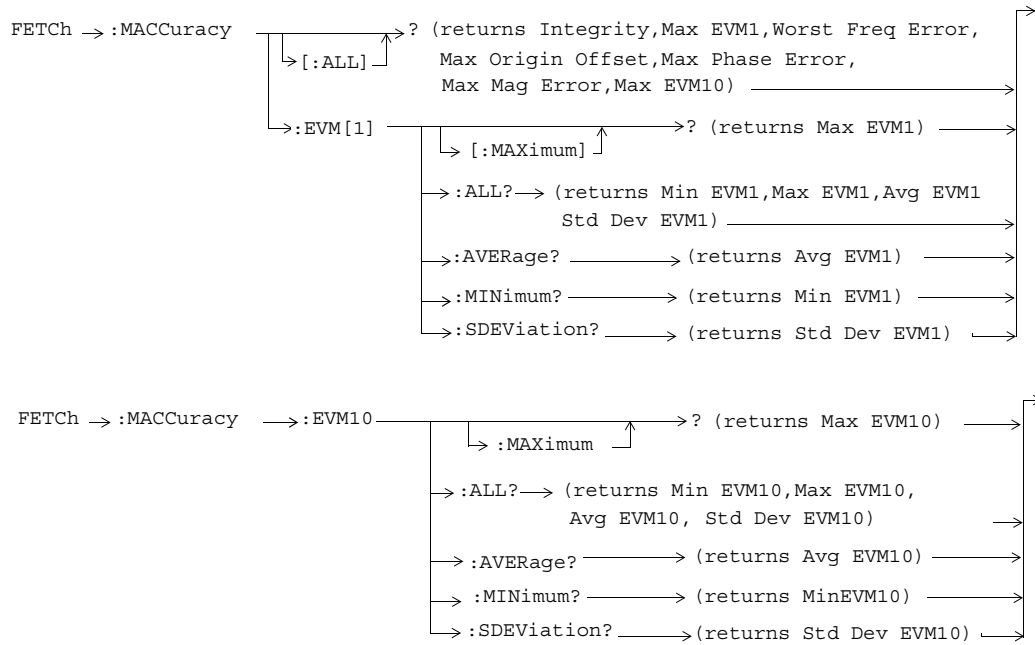

GPIB Syntax for the E1961A

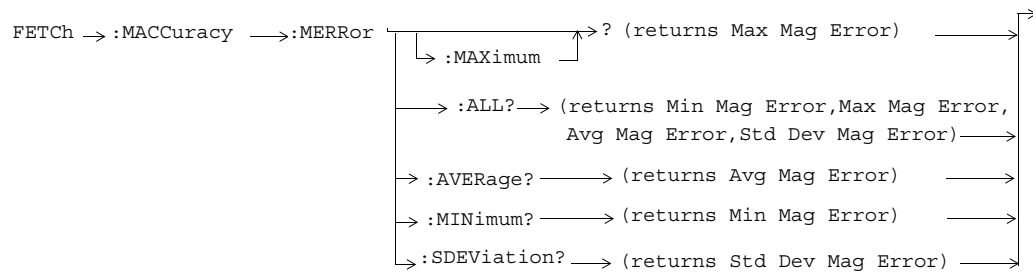
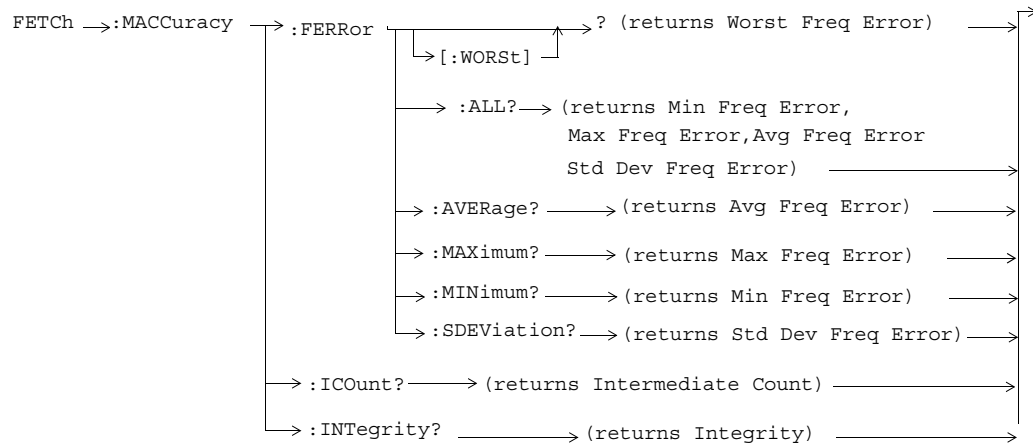

GPIB Syntax for the E1961A

FETCH:SAudio

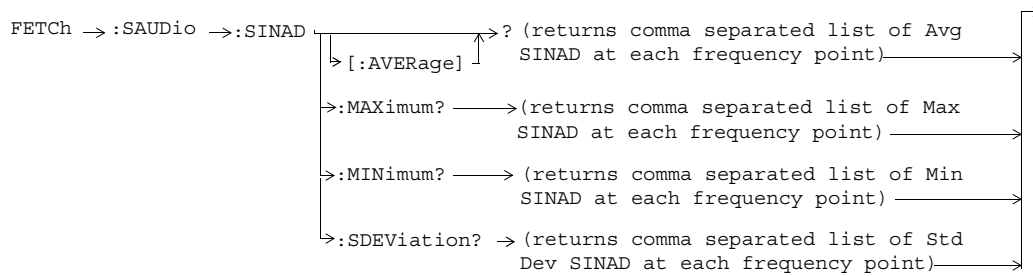
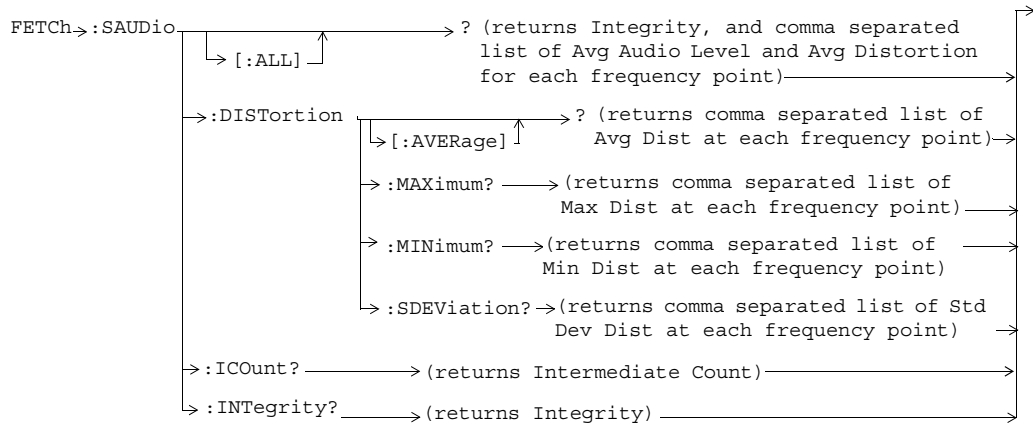

GPIB Syntax for the E1961A

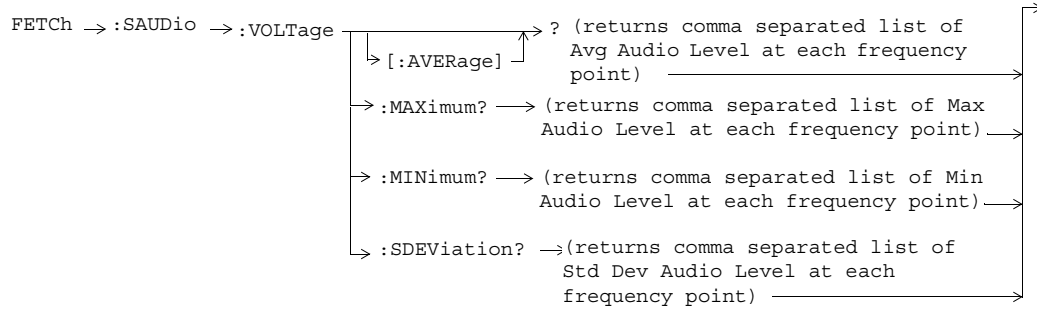

FETCh:SMONitor

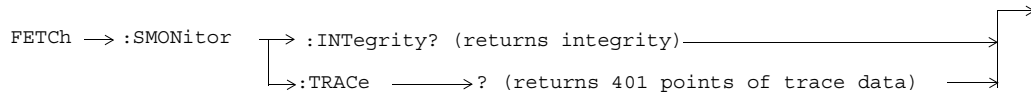

INITiate

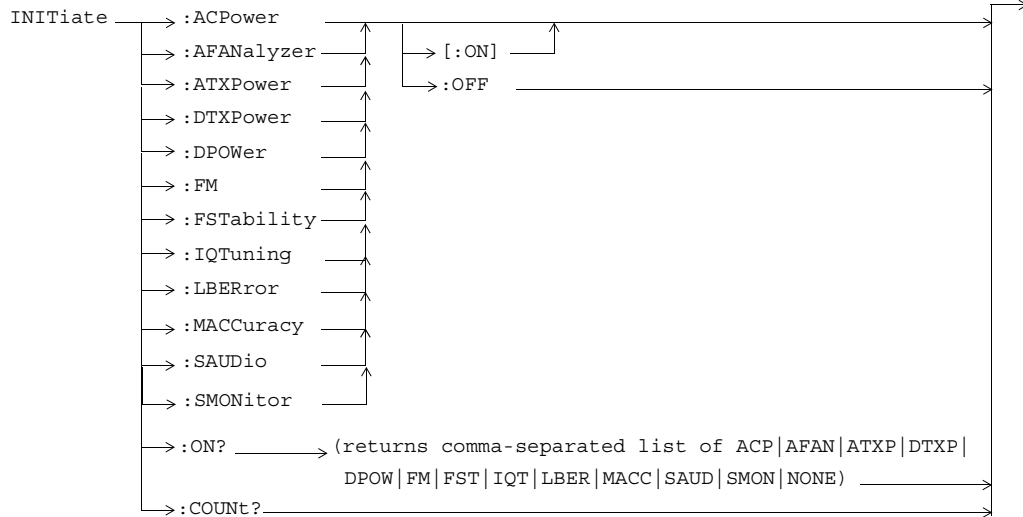

GPIB Syntax for the E1961A

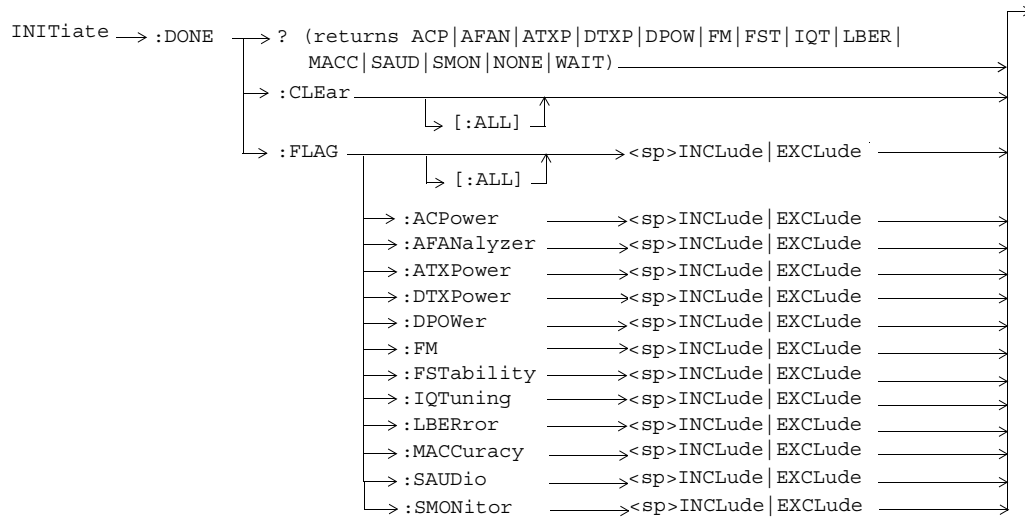

READ

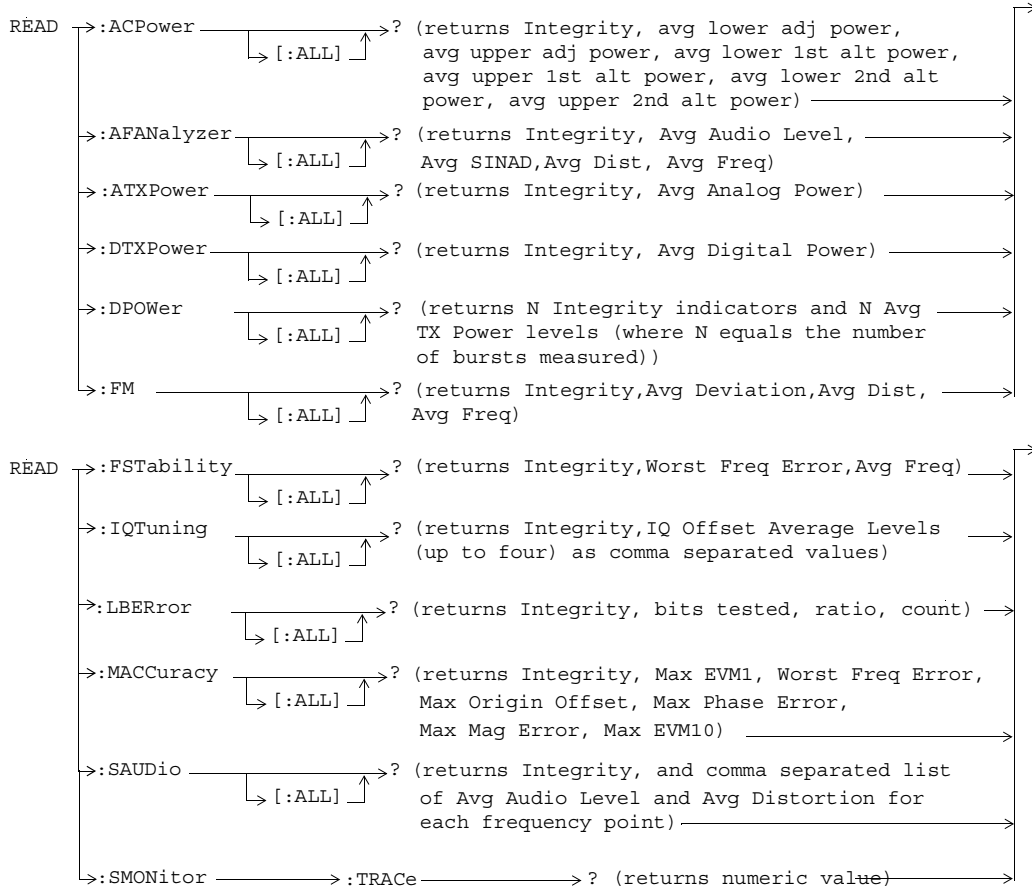

GPIB Syntax for the E1961A

RFAnalyzer

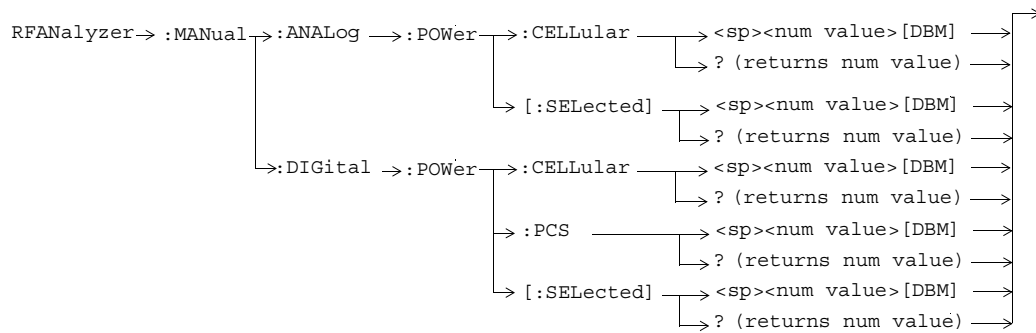
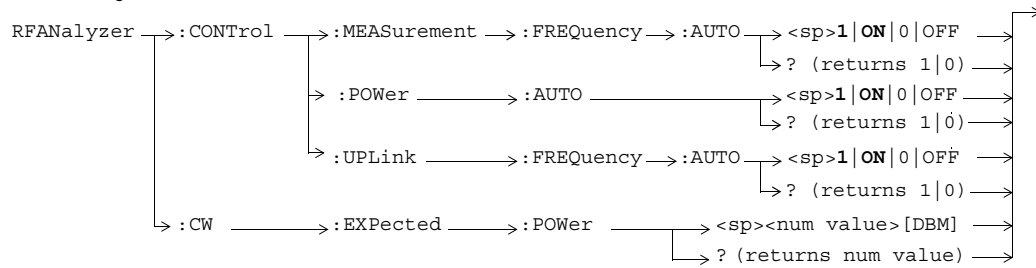

GPIO Syntax for the E1961A

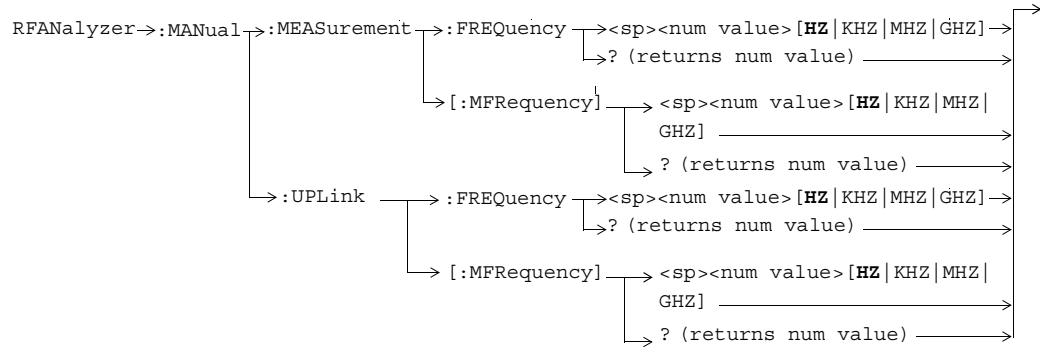

GPIB Syntax for the E1961A

SETup[:ALL]:CONTinuous

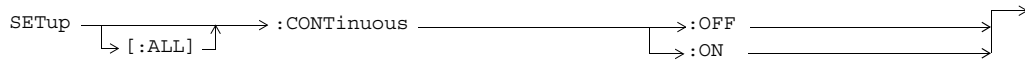

SETup:ACPower

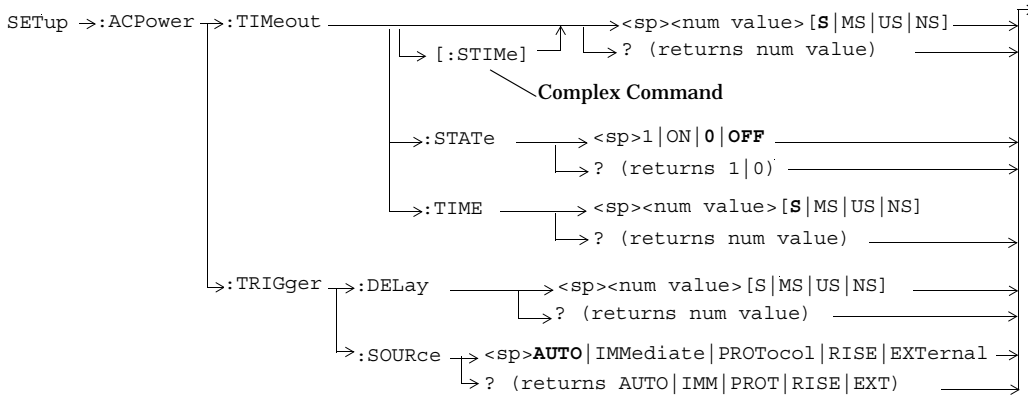
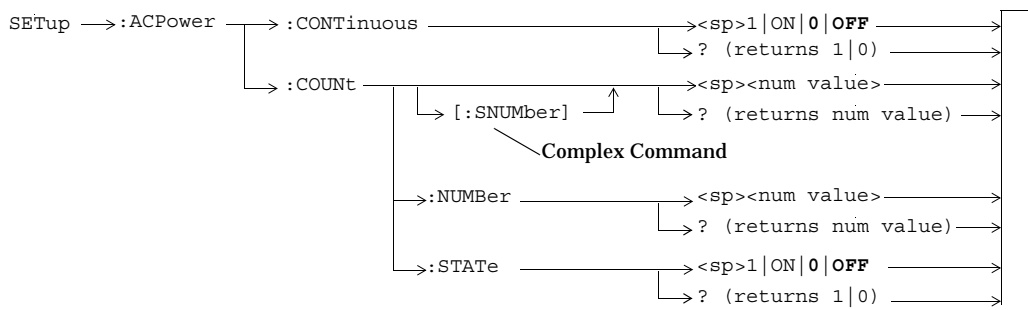

SETup:AFANalyzer

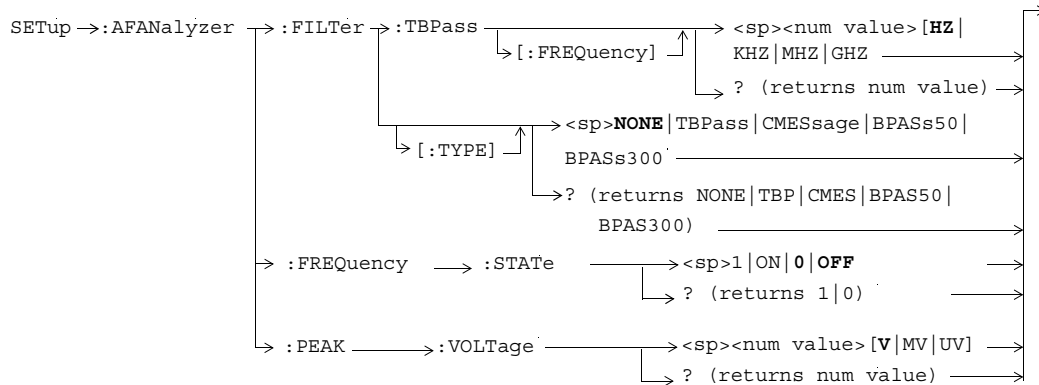
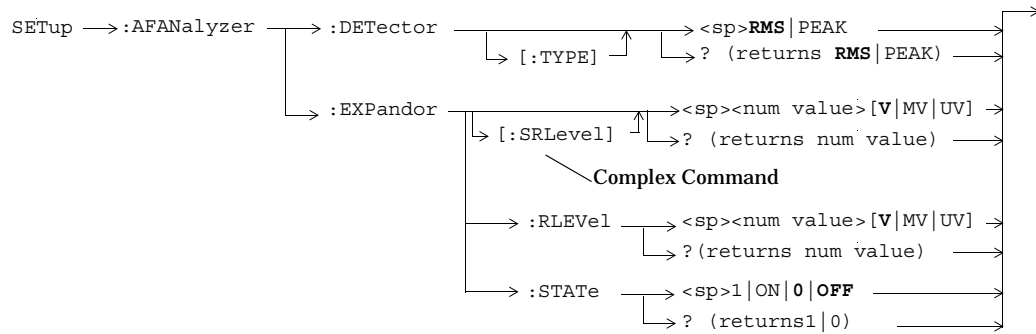
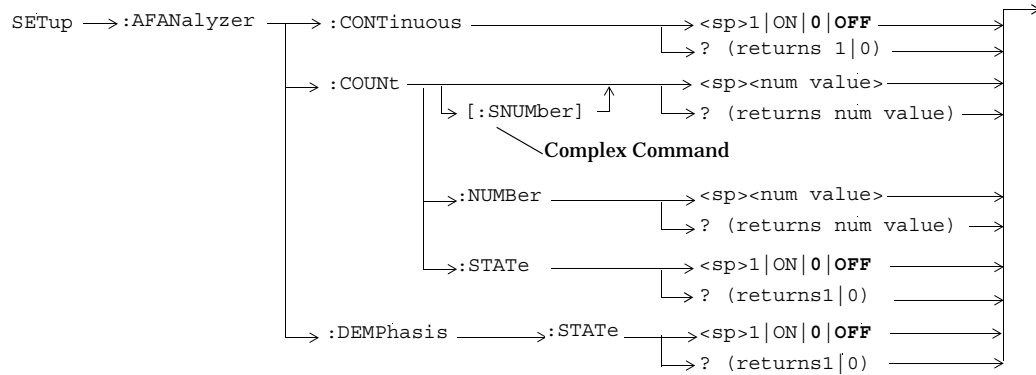

GPIB Syntax for the E1961A

SETup:ATXPower

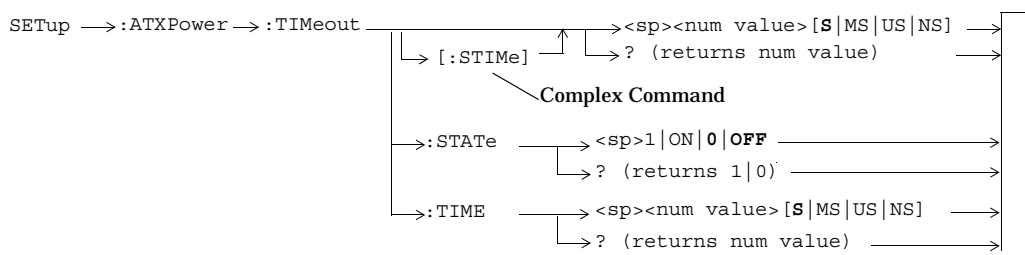
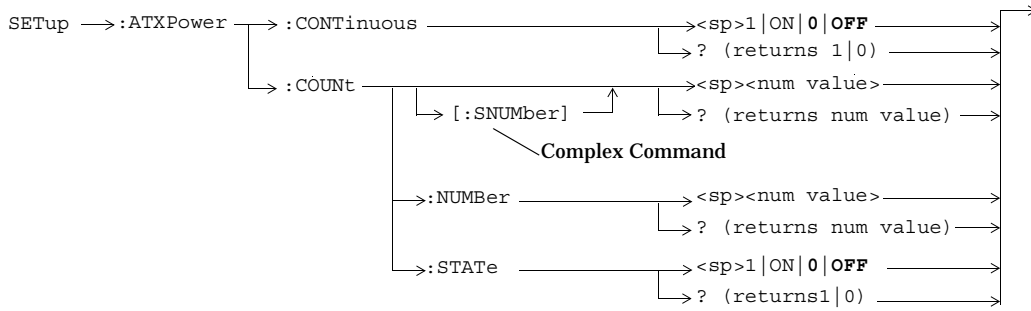

SETup:DPOWER

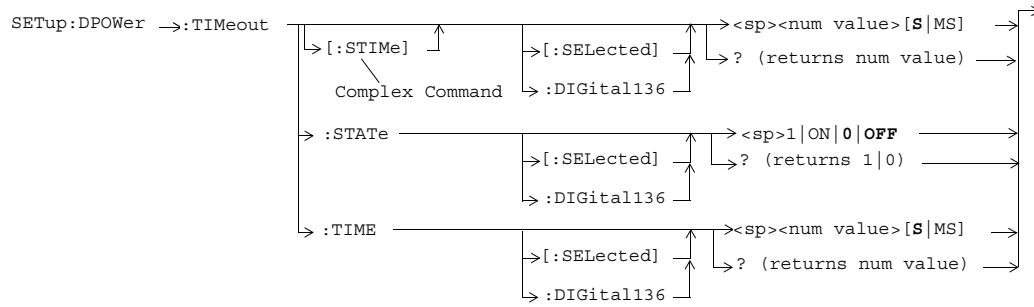
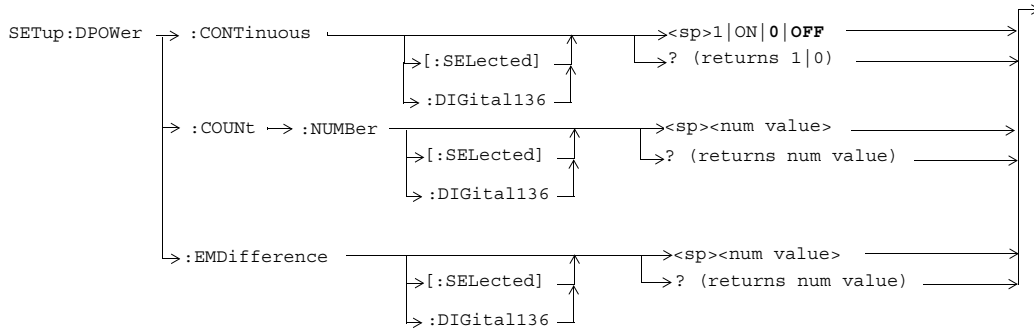

GPIB Syntax for the E1961A

SETup:DTXPower

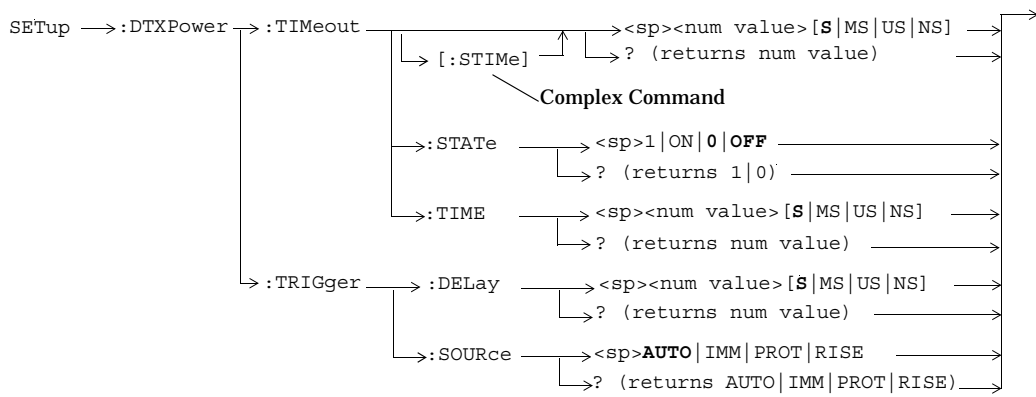
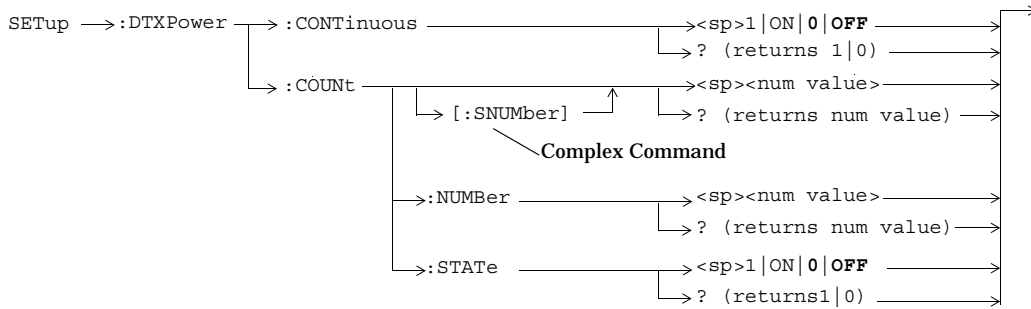

SETup:FM

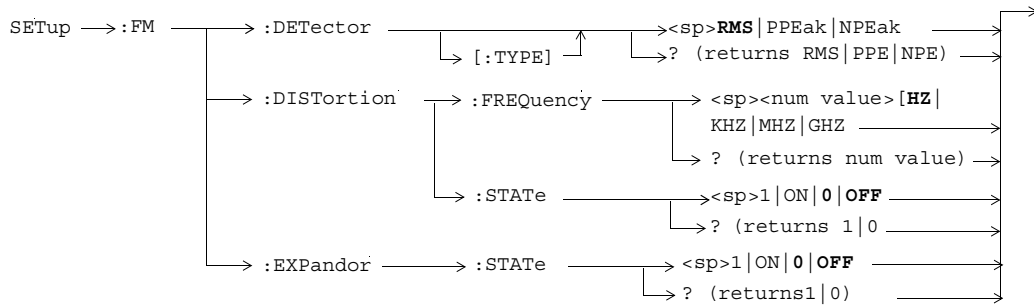
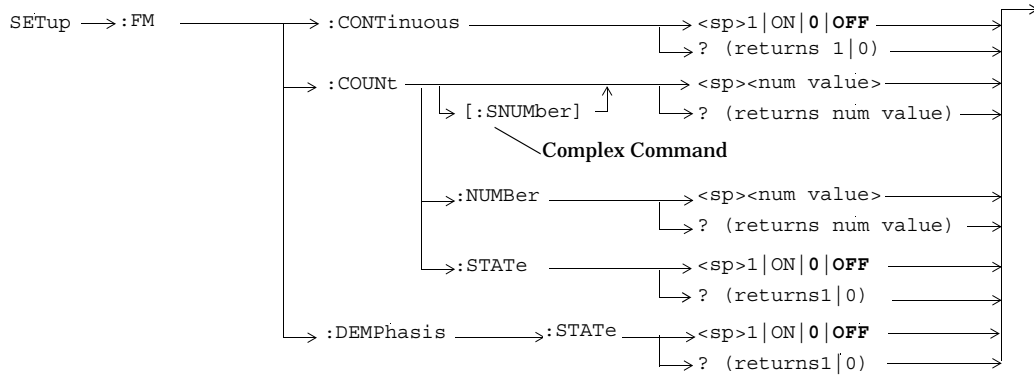

GPIB Syntax for the E1961A

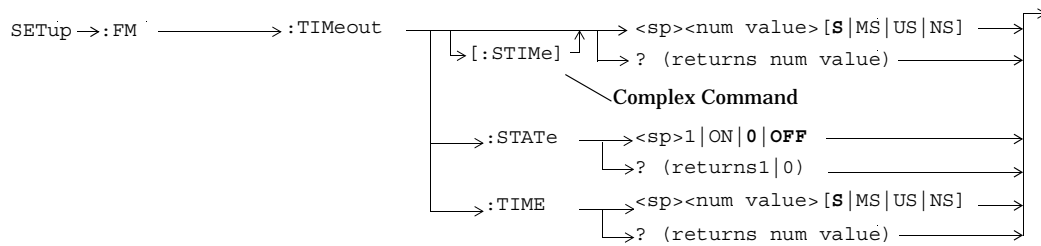
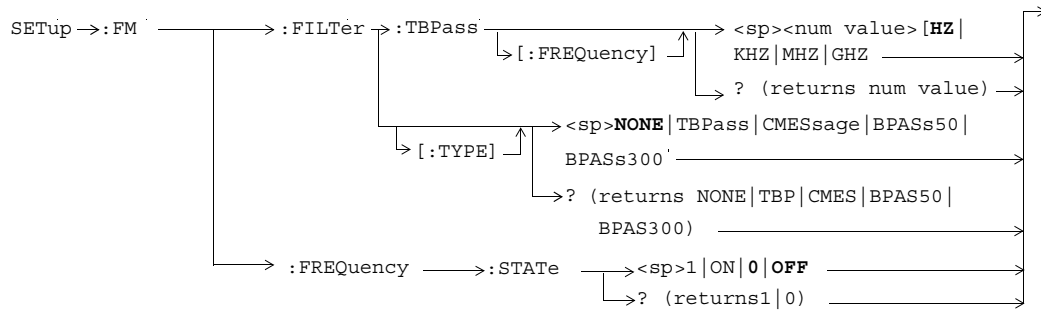

SETup:FSTability

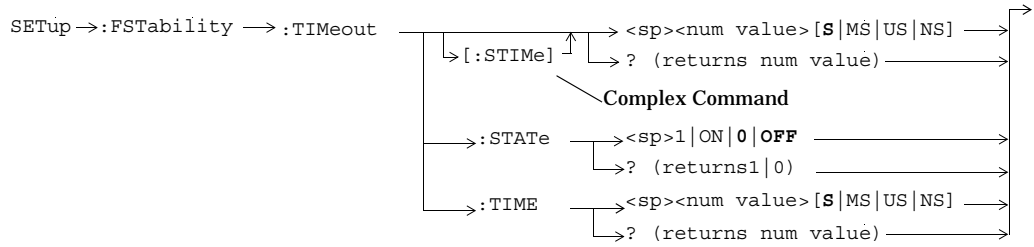
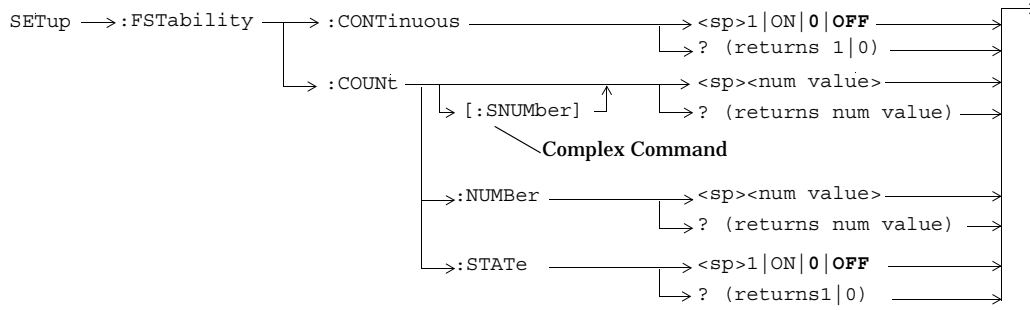

GPIB Syntax for the E1961A

SETup:IQTuning

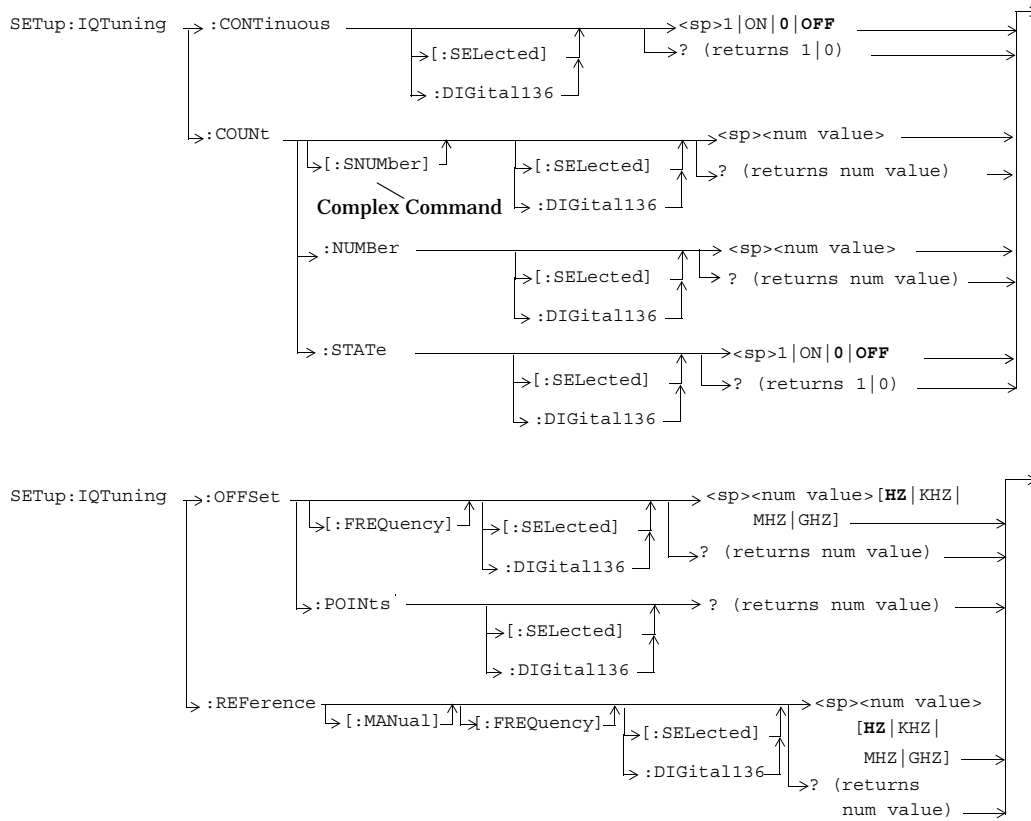

GPIB Syntax for the E1961A

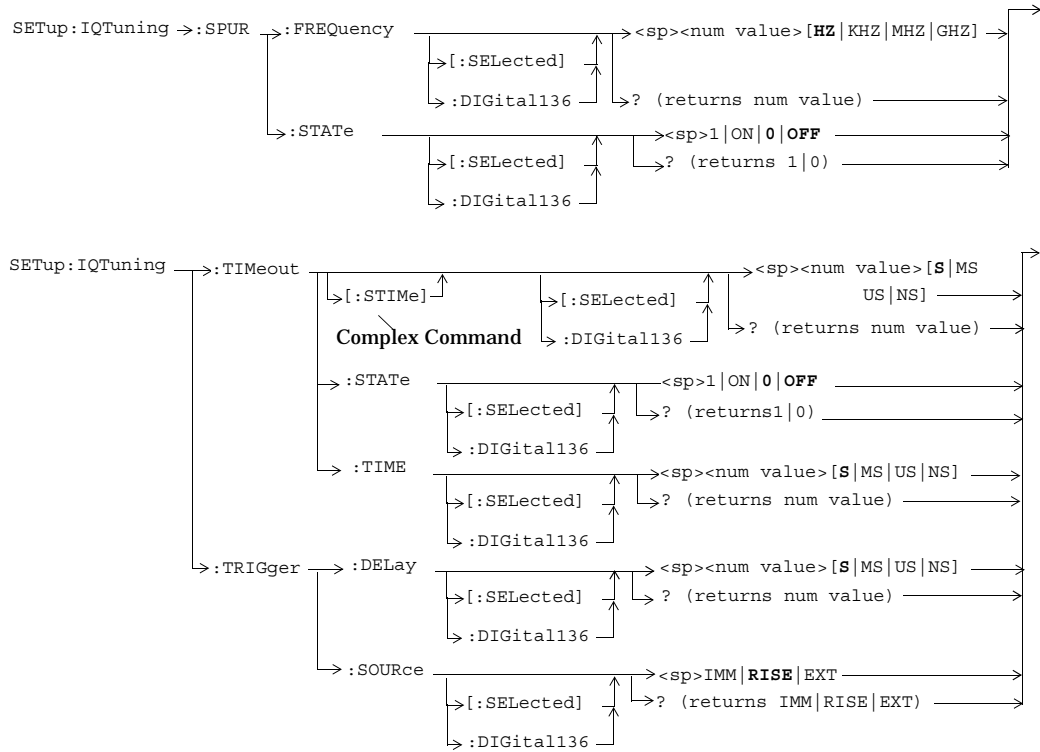

GPIB Syntax for the E1961A

SETup:LBError

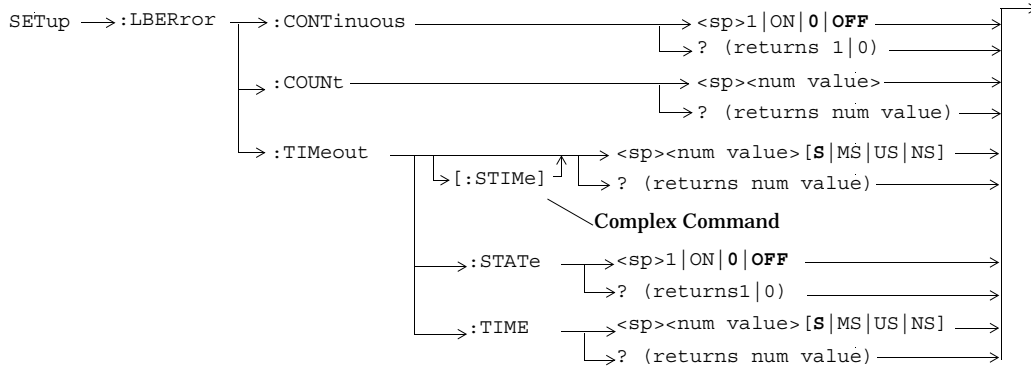

SETup:MACCuracy

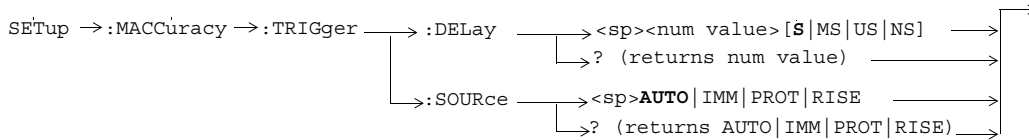
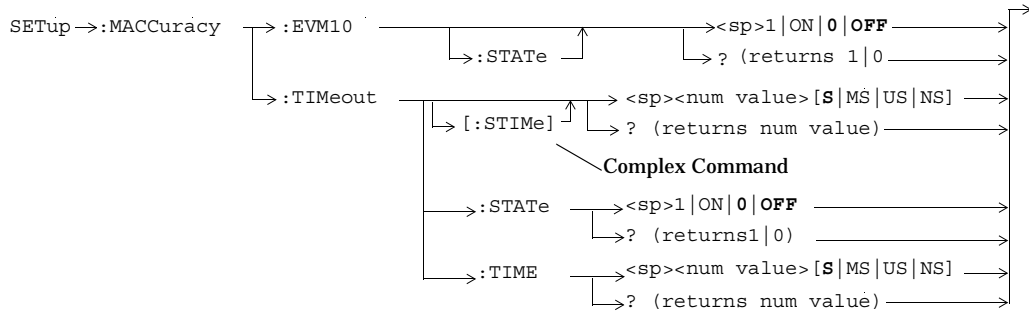
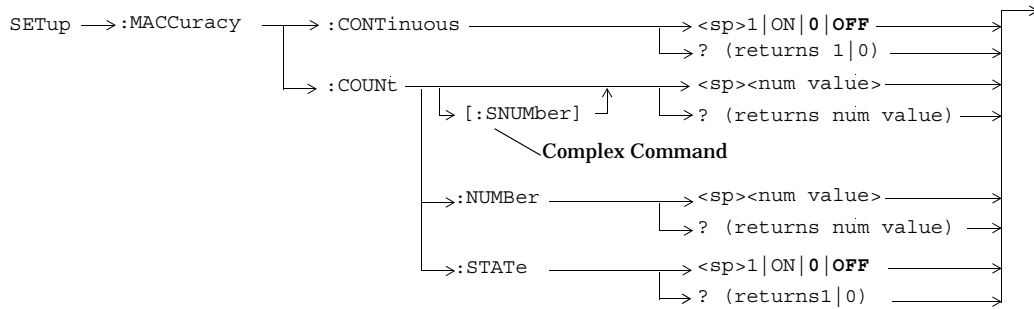

GPIB Syntax for the E1961A

SETup:SAudio

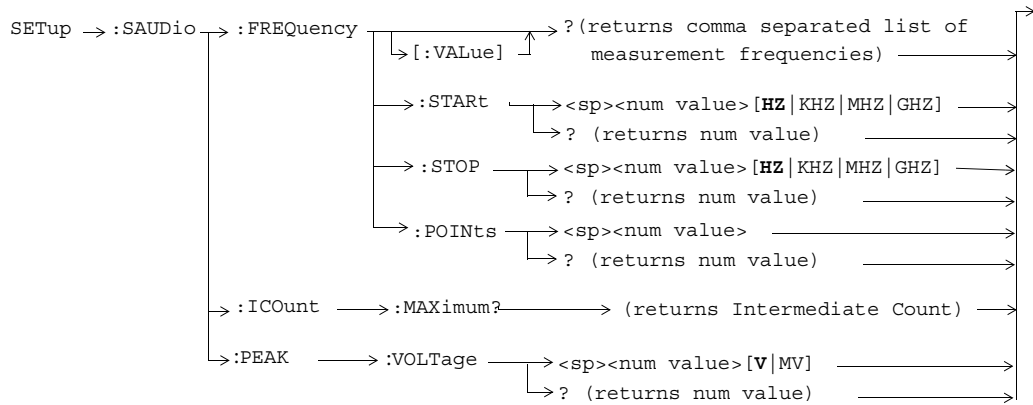
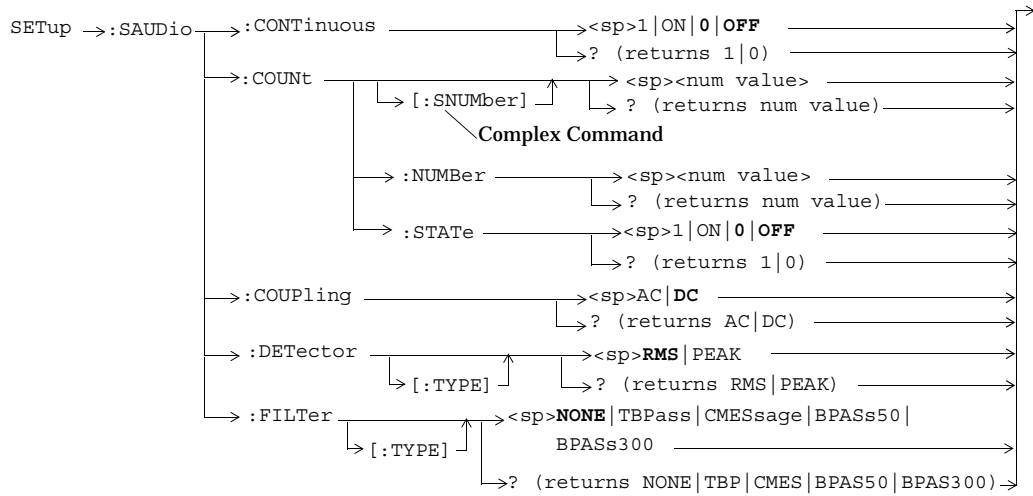

GPIO Syntax for the E1961A

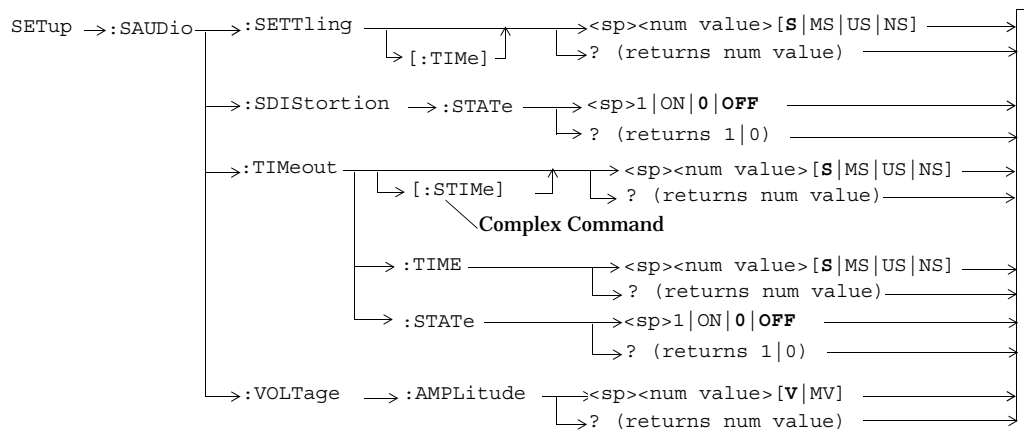

GPIB Syntax for the E1961A

SETup:SMONitor

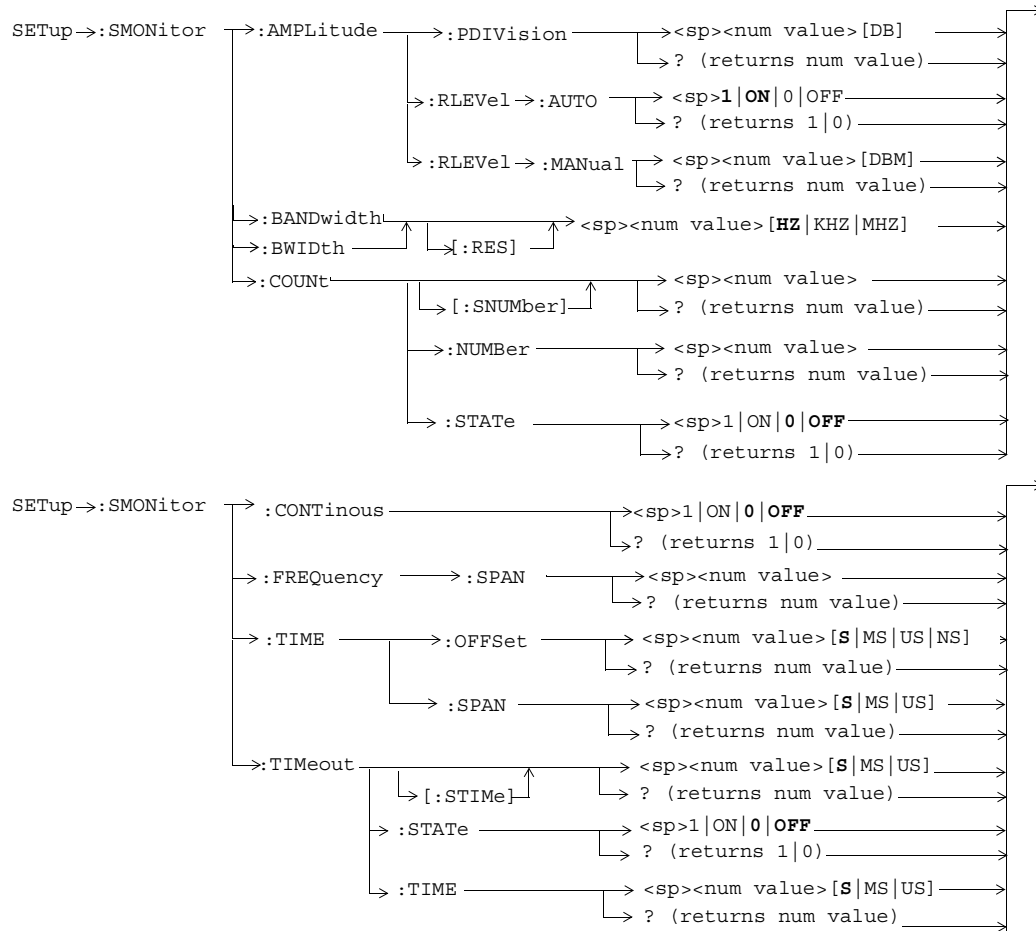

GPIO Syntax for the E1961A

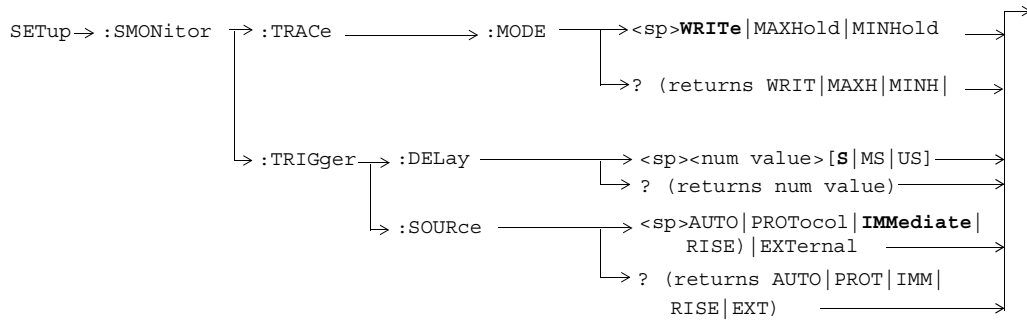

GPIB Syntax for the E1961A

STATus:OPERation

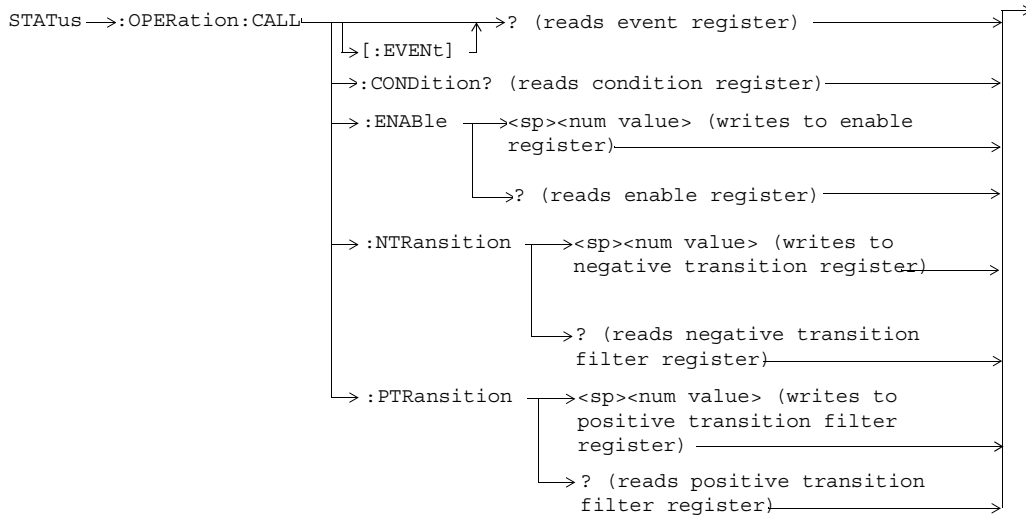
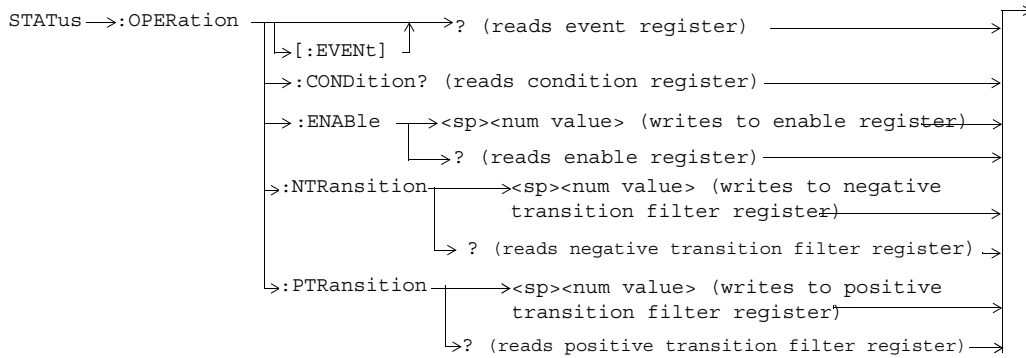

GPIB Syntax for the E1961A

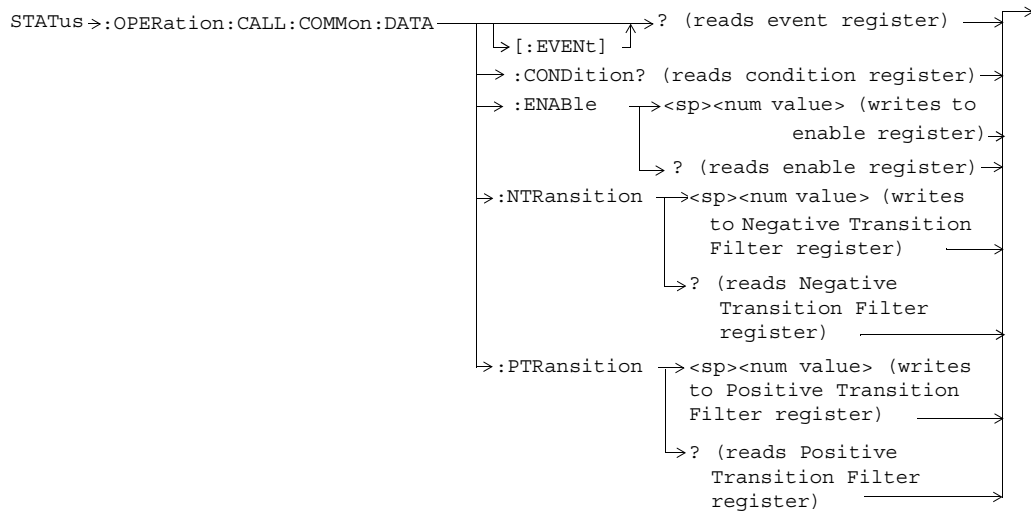
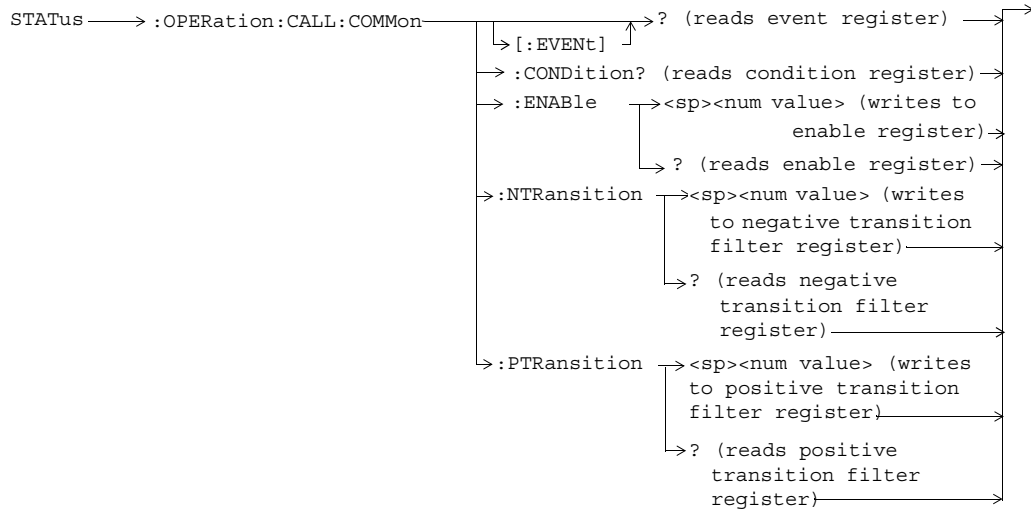

GPIO Syntax for the E1961A

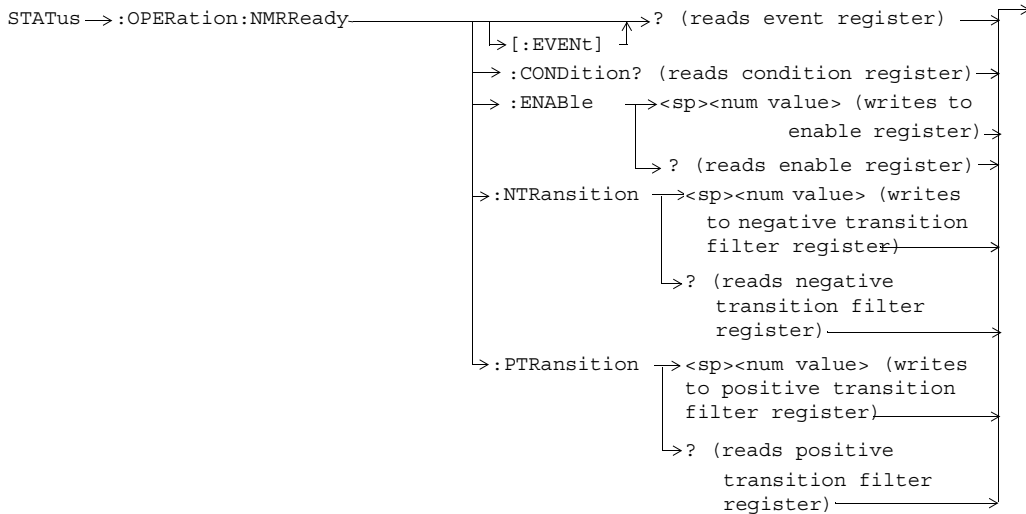
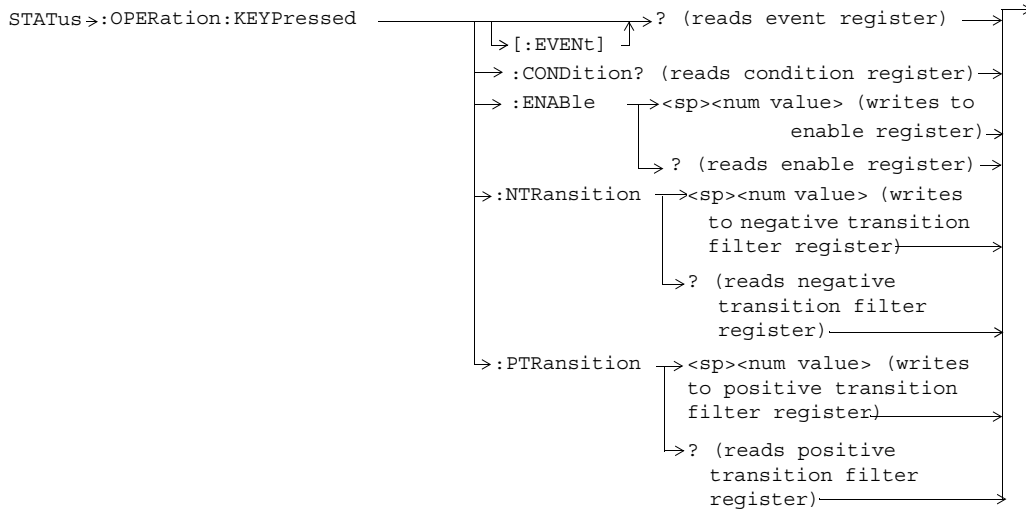

GPIB Syntax for the E1961A

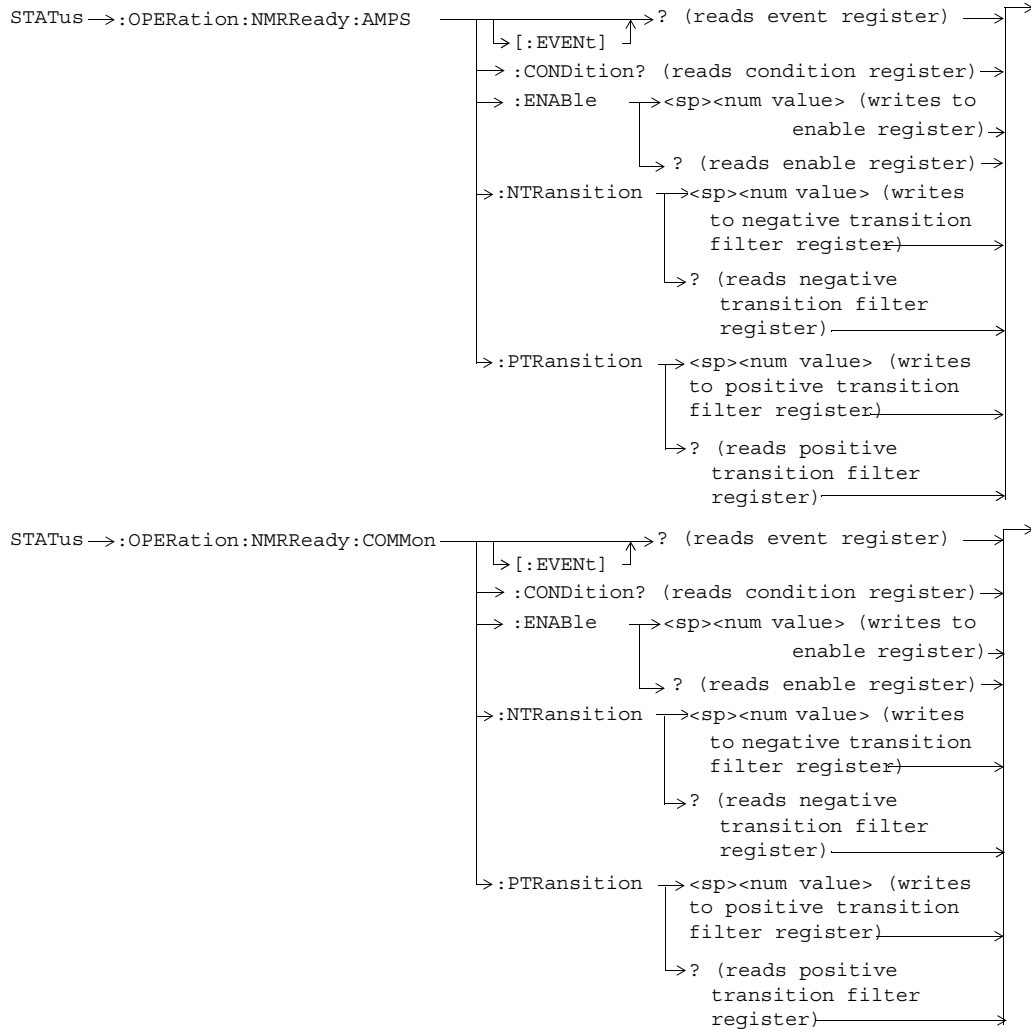

GPiB Syntax for the E1961A

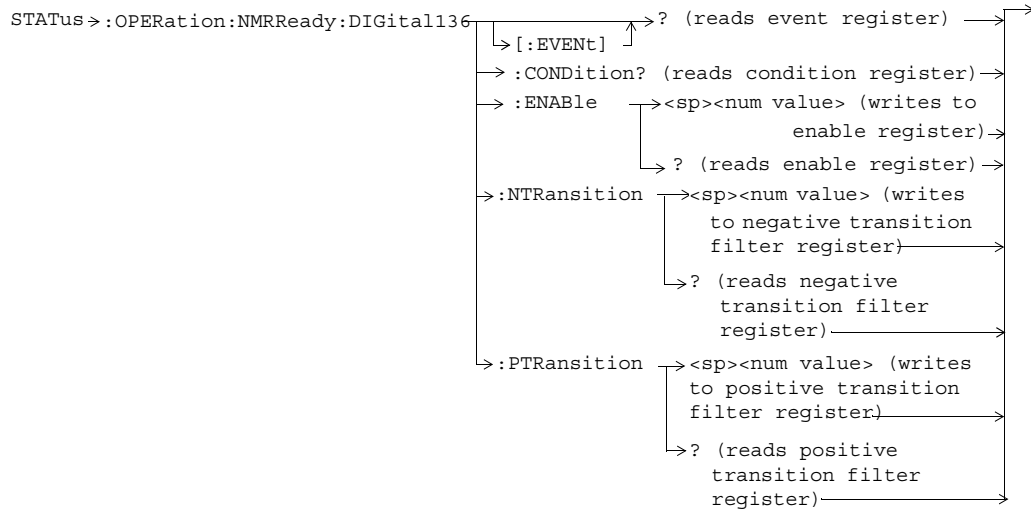

STATus:PRESet

STATus → :PRESet →

STATus:PRESet

| Function | Presets the Status Subsystem Sets all Enable Registers to 0 (not enabled). Sets all Positive Transition Registers (PTR) to 1 (positive transitions enabled). Sets all Negative Transition Registers (NTR) to 0 (negative transitions disabled). |
|----------|--|
| | |

STATus:QUEStionable

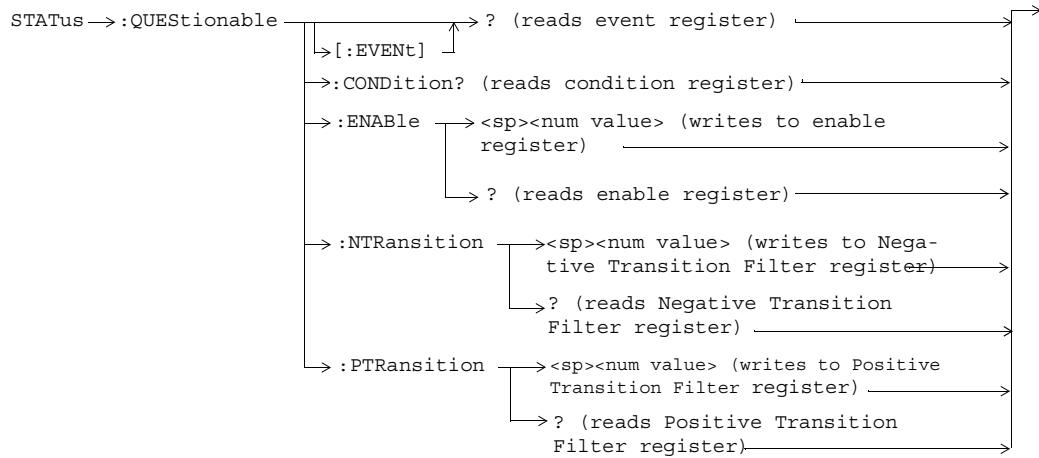

GPIB Syntax for the E1961A

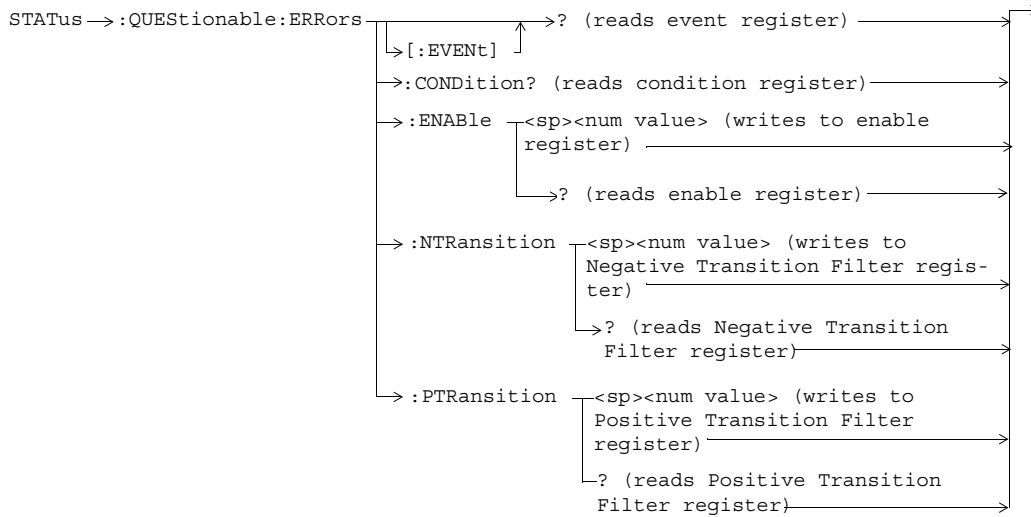
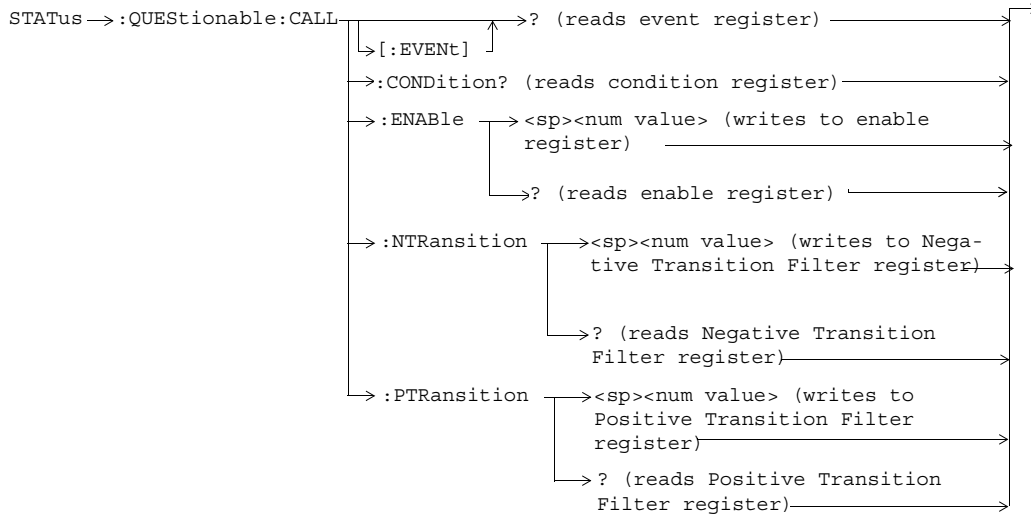

GPIB Syntax for the E1961A

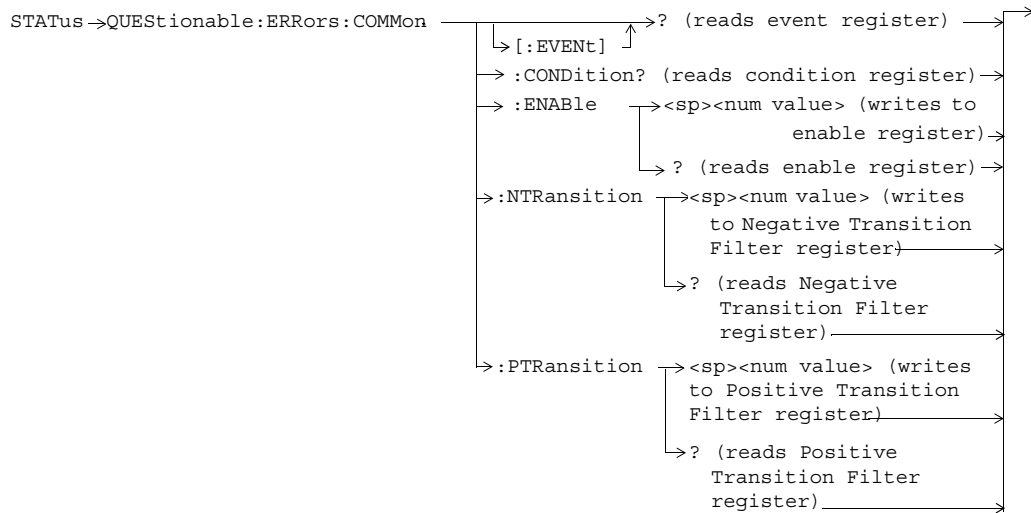
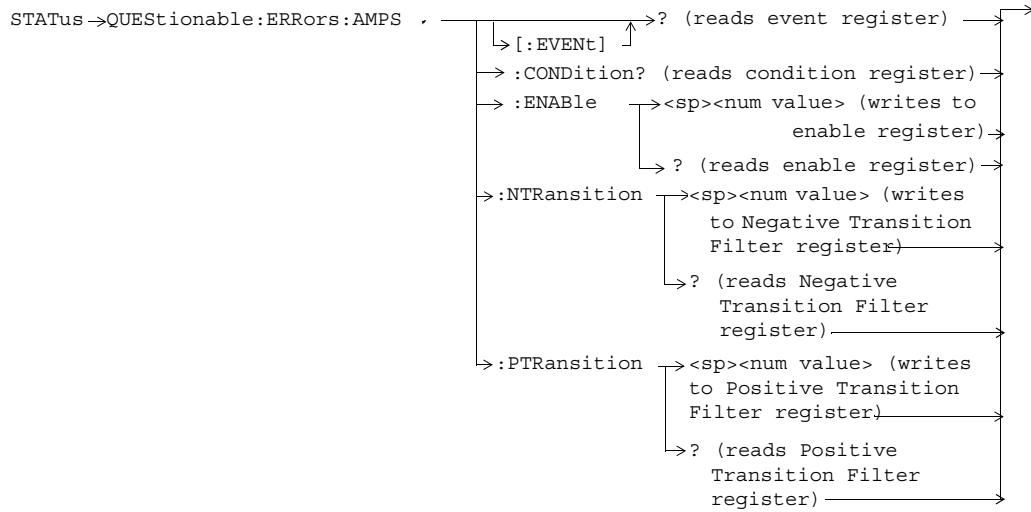

GPIB Syntax for the E1961A

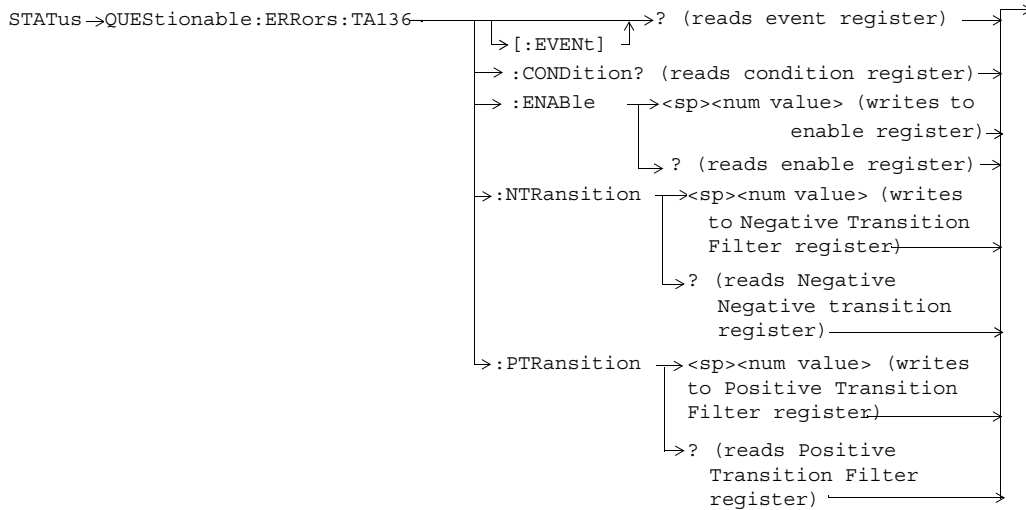
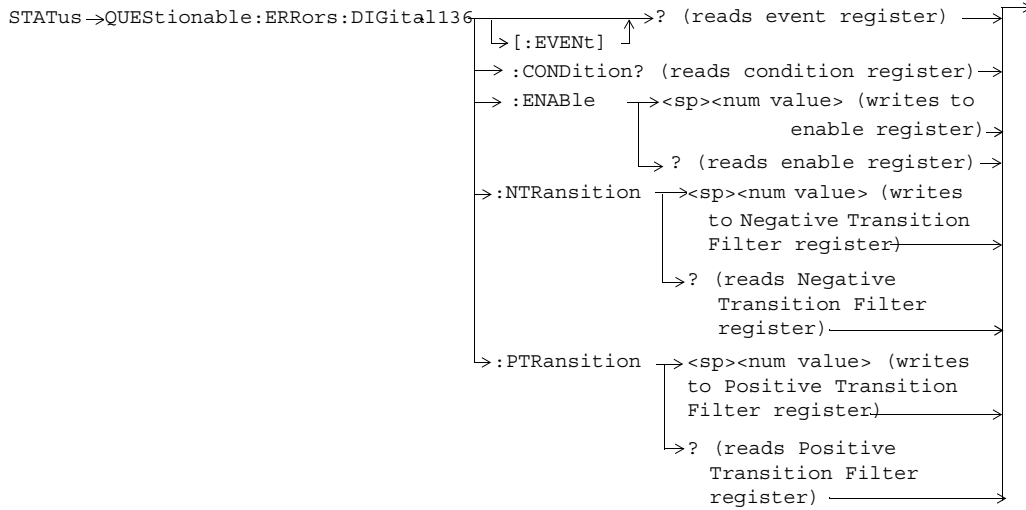

GPIB Syntax for the E1961A

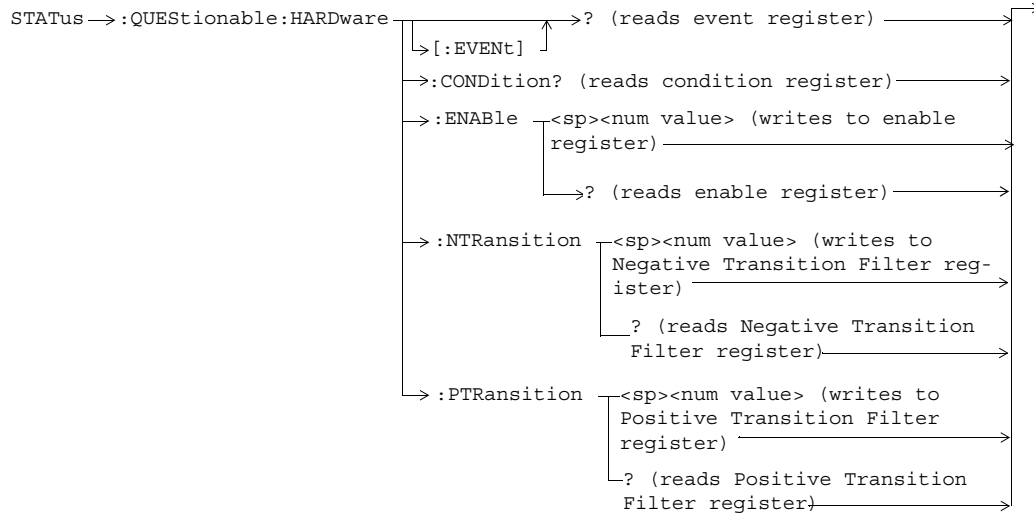

```

OUTPUT 714;"STATUS:QUESTIONABLE:EVENT?" !Queries and clears the Questionable Event
!Register
OUTPUT 714;"STATUS:QUESTIONABLE:CONDITION?" !Queries and clears the Questionable Condition
!Register
OUTPUT 714;"STATUS:QUESTIONABLE:ENABLE 1024" !Sets the Questionable Enable Register
!for bit 10
OUTPUT 714;"STATUS:QUESTIONABLE:NTRANSITION 2" !Sets the Questionable Negative
!Transition Filter Register for bit 1
OUTPUT 714;"STATUS:QUESTIONABLE:PTRANSITION 2" !Sets the Questionable Positive
!Transition Filter Register for bit 1

OUTPUT 714;"STATUS:QUESTIONABLE:CALL:EVENT?" !Queries and clears the Questionable
!Call Event Register
OUTPUT 714;"STATUS:QUESTIONABLE:CALL:CONDITION?" !Queries and clears the Questionable
!Call Condition Register
OUTPUT 714;"STATUS:QUESTIONABLE:CALL:ENABLE 1024" !Sets the Questionable
!Call Enable Register for bit 10
OUTPUT 714;"STATUS:QUESTIONABLE:CALL:NTRANSITION 2" !Sets the Questionable Call
!Negative Transition Filter Register
!for bit 1
OUTPUT 714;"STATUS:QUESTIONABLE:CALL:PTRANSITION 2" !Sets the Questionable Call
!Positive Transition Filter Register
!for bit 1

OUTPUT 714;"STATUS:QUESTIONABLE:ERRORS:EVENT?" !Queries and clears the Questionable
!Errors Event Register
OUTPUT 714;"STATUS:QUESTIONABLE:ERRORS:CONDITION?" !Queries and clears the Questionable

```

GPIB Syntax for the E1961A

```
                                !Errors Condition Register
OUTPUT 714;"STATUS:QUESTIONABLE:ERRORS:ENABLE 1024" !Sets the Questionable
                                !Errors Enable
                                !Register for bit 10
OUTPUT 714;"STATUS:QUESTIONABLE:ERRORS:NTRANSITION 2" !Sets the Questionable Errors
                                !Negative Transition Filter Register
                                !for bit 1
OUTPUT 714;"STATUS:QUESTIONABLE:ERRORS:PTRANSITION 2" !Sets the Questionable Errors
                                !Positive Transition Filter Register
                                !for bit 1

OUTPUT 714;"STATUS:QUESTIONABLE:ERRORS:COMMON:EVENT?" !Queries and clears the Questionable
                                !Errors Common Event Register
OUTPUT 714;"STATUS:QUESTIONABLE:ERRORS:COMMON:CONDITION?" !Queries the and clears the
                                !Questionable Errors
                                !Common Condition Register
OUTPUT 714;"STATUS:QUESTIONABLE:ERRORS:COMMON:ENABLE 1024" !Sets the Questionable
                                !Errors Common Enable
                                !Register for bit 10
OUTPUT 714;"STATUS:QUESTIONABLE:ERRORS:COMMON:NTRANSITION 2" !Sets the Questionable Errors
                                !Common Negative Transition
                                !Register for bit 1
OUTPUT 714;"STATUS:QUESTIONABLE:ERRORS:COMMON:PTRANSITION 2" !Sets the Questionable Errors
                                !Common Positive Transition
                                !Register for bit 1

OUTPUT 714;"STATUS:QUESTIONABLE:ERRORS:AMPS:EVENT?" !Queries and clears the Questionable
                                !Errors AMPS Event Register
OUTPUT 714;"STATUS:QUESTIONABLE:ERRORS:AMPS:CONDITION?" !Queries and clears the Questionable
                                !Errors AMPS Condition Register
OUTPUT 714;"STATUS:QUESTIONABLE:ERRORS:AMPS:ENABLE 1024" !Sets the Questionable
                                !Errors AMPS Enable
                                !Register for bit 10
OUTPUT 714;"STATUS:QUESTIONABLE:ERRORS:AMPS:NTRANSITION 2" !Sets the Questionable Errors
                                !AMPS Negative Transition
                                !Filter Register for bit 1
OUTPUT 714;"STATUS:QUESTIONABLE:ERRORS:AMPS:PTRANSITION 2" !Sets the Questionable Errors
                                !AMPS Positive Transition
                                !Filter Register for bit 1

OUTPUT 714;"STATUS:QUESTIONABLE:ERRORS:DIGITAL136:EVENT?" !Queries and clears the
                                !Questionable Errors
                                !Digital136 Event Register
OUTPUT 714;"STATUS:QUESTIONABLE:ERRORS:DIGITAL136:CONDITION?" !Queries and clears the
                                !Questionable Errors
                                !Digital136 Condition Register
OUTPUT 714;"STATUS:QUESTIONABLE:ERRORS:DIGITAL136:ENABLE 1024" !Sets the Questionable
                                !Errors Digital136 Enable
                                !Register for bit 10
OUTPUT 714;"STATUS:QUESTIONABLE:ERRORS:DIGITAL136:NTRANSITION 2" !Sets the Questionable
                                !Errors Digital136 Negative
                                !Transition Filter
                                !Register for bit 1
OUTPUT 714;"STATUS:QUESTIONABLE:ERRORS:DIGITAL136:PTRANSITION 2" !Sets the Questionable
```

GPIB Syntax for the E1961A

!Errors Digital136 Positive
!Transition Filter
!Register for bit 1

```
OUTPUT 714;"STATUS:QUESTIONABLE:ERRORS:TA136:EVENT?" !Queries and clears the
!Questionable Errors
!TA136 Event Register
OUTPUT 714;"STATUS:QUESTIONABLE:ERRORS:TA136:CONDITION?" !Queries and clears the
!Questionable Errors
!TA136 Condition Register
OUTPUT 714;"STATUS:QUESTIONABLE:ERRORS:TA136:ENABLE 1024" !Sets the Questionable
!Errors TA136 Enable
!Register for bit 10
OUTPUT 714;"STATUS:QUESTIONABLE:ERRORS:TA136:NTRANSITION 2" !Sets the Questionable
!Errors TA136 Negative
!Transition Filter
!Register for bit 1
OUTPUT 714;"STATUS:QUESTIONABLE:ERRORS:TA136:PTRANSITION 2" !Sets the Questionable
!Errors TA136 Positive
!Transition Filter
!Register for bit 1

OUTPUT 714;"STATUS:QUESTIONABLE:HARDWARE:EVENT?" !Queries and clears the Questionable
!Hardware Event Register
OUTPUT 714;"STATUS:QUESTIONABLE:HARDWARE:CONDITION?" !Queries and clears the Questionable
!Hardware Condition Register
OUTPUT 714;"STATUS:QUESTIONABLE:HARDWARE:ENABLE 1024" !Sets the Questionable
!Hardware Enable
!Register for bit 10
OUTPUT 714;"STATUS:QUESTIONABLE:HARDWARE:NTRANSITION 2" !Sets the Questionable
!Hardware Negative Transition Filter
!Register for bit 1
OUTPUT 714;"STATUS:QUESTIONABLE:HARDWARE:PTRANSITION 2" !Sets the Questionable
!Hardware Positive Transition Filter
!Register for bit 1
```

Status Byte Register

***STB?**

*STB? _____ ↘

NOTE The Status Byte Register can also be read with a serial poll. For example, the command "Status_byte = SPOLL(714)" would perform a serial poll of the Status Byte Register, returning and releasing RQS (bit 6).

GPiB Syntax for the E1961A

Status Byte Register Bit Assignments

| Bit Number | Binary Weighting | Label | Description |
|------------|------------------|---------------------------------------|---|
| 7 | 128 | STATus: OPERation | Summarizes the STATus: OPERation Status Register, which fans out to the NMRReady and CALL Status Registers. |
| 6 | 64 | RQS (SRQ TRUE?)/Master Summary Status | RQS is read by a serial poll (SPOLL) Master Summary Status is read by a *STB? query - defined by IEEE 488.2 |
| 5 | 32 | Standard Event Status Register | Summarizes the Standard Event Status Register |
| 4 | 16 | Message Available | SCPI - Defined |
| 3 | 8 | STATus: QUESTionable Status Register | Summary Message comes from the STATus: QUESTionable Status Register, which fans out to the CALL and HARDware Status Registers |
| 2 | 4 | Error/ Event Queue | SCPI - Defined |
| 1 | 2 | Reserved | |
| 0 | 1 | Reserved | |

Status Byte Register Bit Assignments

Standard Event Status Register

*ESR?

*ESR? → Reads and clears the Std Event Status Register. →

*ESE?

*ESE? → Reads the Std Event Status Register Enable Register →

*ESE

*ESE → Writes to the Std Event Status Register Enable Register →

Standard Event Status Register Bit Assignment

| Bit Number | Binary Weighting | Condition | Description |
|------------|------------------|--------------------------|---|
| 15 | 32768 | Reserved by IEEE. | This bit will always be 0. |
| 14 | 16384 | Reserved by IEEE. | This bit will always be 0. |
| 13 | 8192 | Reserved by IEEE. | This bit will always be 0. |
| 12 | 4096 | Reserved by IEEE. | This bit will always be 0. |
| 11 | 2048 | Reserved by IEEE. | This bit will always be 0. |
| 10 | 1024 | Reserved by IEEE. | This bit will always be 0. |
| 9 | 512 | Reserved by IEEE. | This bit will always be 0. |
| 8 | 256 | Reserved by IEEE. | This bit will always be 0. |
| 7 | 128 | Power On | This bit is set to 1 if the power supply has been turned off and on since the last time this register was read or otherwise cleared. Defined in "IEEE Std. 488.2-1992", 11.5.1.1.2 |
| 6 | 64 | Reserved for future use. | This bit will always be 0. |
| 5 | 32 | Command Error | This bit is set to 1 if the test set detects an error while trying to process a command. The following events cause a command error: <ul style="list-style-type: none"> An IEEE 488.2 syntax error. The test set received a message that did not follow the syntax defined by the standard. A semantic error. For example the test set received an incorrectly spelled command. The test set received a group execution trigger (GET) inside a program message |
| 4 | 16 | Execution Error | This bit is set to 1 if the test set detects an error while trying to execute a command. The following events cause a execution error: <ul style="list-style-type: none"> A <PROGRAM DATA> element received in a command is outside the legal range for the test set, or it is inconsistent with the operation of the test set. The test set could not execute a valid command due to some test set hardware/firmware condition. |
| 3 | 8 | Device Dependent Error | This bit is set to 1 if a test set operation does not execute properly due to an internal condition (such as, overrange). This bit indicates that the error was not a command, query, or execution error. |

GPIB Syntax for the E1961A

| Bit Number | Binary Weighting | Condition | Description |
|------------|------------------|--------------------------|--|
| 2 | 4 | Query Error | This bit is set to 1 if an error has occurred while trying to read the test set's output queue. The following events cause a query error: <ul style="list-style-type: none">• An attempt is made to read data from the output queue when no data is present or is pending.• Data in the output queue has been lost. An example of this would be an output queue overflow. |
| 1 | 2 | Reserved for future use. | This bit will always be 0. |
| 0 | 1 | Operation Complete | This bit is set to 1 when the test set has completed all pending operations and is ready to accept new commands. This bit is only generated in response to the *OPC IEEE 488.2 common command. |

SYSTem:APPLication

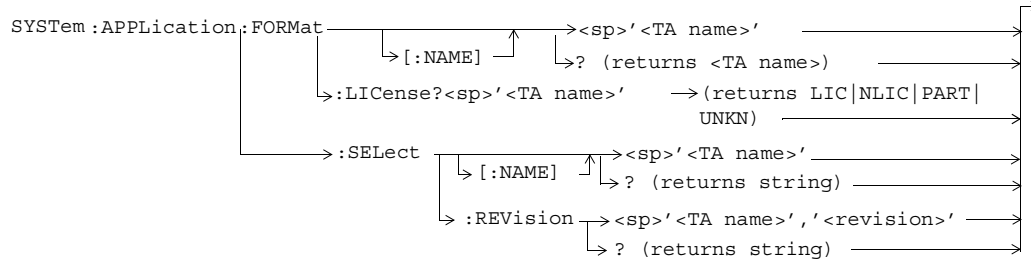
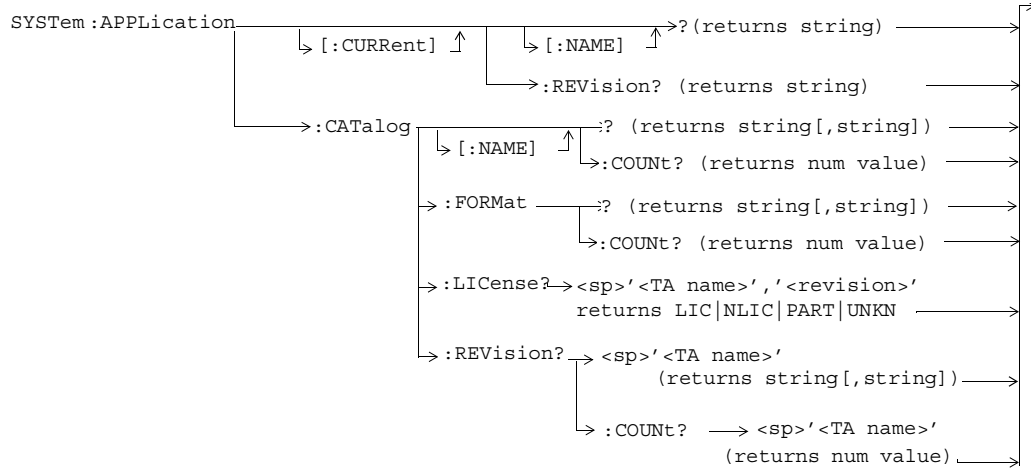

SYSTem:BEEPer

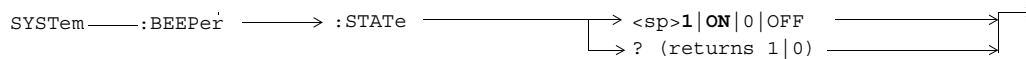

SYSTem:CONFIgure:INFormation:HARDware:VERBose?

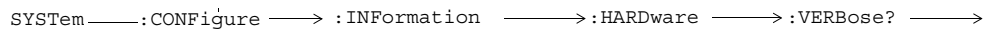

GPIB Syntax for the E1961A

SYSTEM:COMMunicate

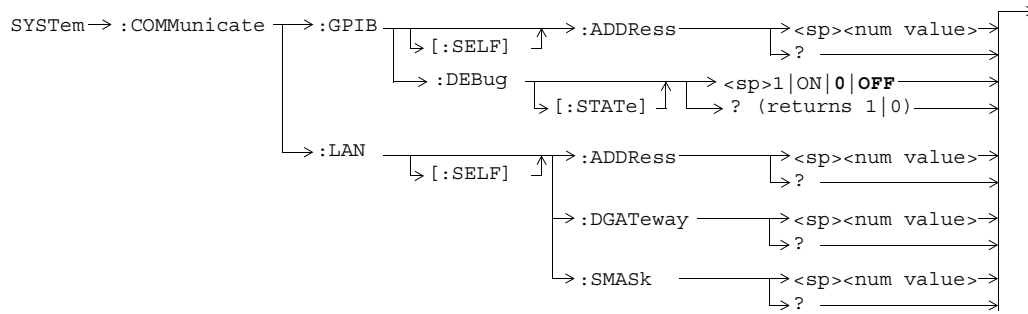

GPIB Syntax for the E1961A

SYSTem:ERRor?

SYSTem → :ERRor? →

SYSTem:MEASurement:RESet

SYSTem → :MEASurement → :RESet →

SYSTem:PRESet

SYSTem → :PRESet [1] →
→ :PRESet2 (full preset trigger arm continuous) →
→ :PRESet3 (partial preset trigger arm no change) →

SYSTem:ROSCillator

SYSTem → :ROSCillator → ? (returns EXT|INT) →
↳[:TIMEbase] →
↳:LOCKed? (returns 1|0) →

SYSTem:SYNChronized

SYSTem → :SYNChronized → ? (returns num value) →

IEEE 488.2 Common Commands

Description

***CLS** The *CLS, clear status command, is defined in "IEEE Std 488.2-1992", 10.3. This command will also clear and close the error message screen on the test set's display.

***ESE** The *ESE, standard event status enable command, is defined in "IEEE Std 488.2-1992", 10.10.

***ESE?** The *ESE?, standard event status enable query, is defined in "IEEE Std 488.2-1992", 10.11.

***ESR?** The *ESR?, standard event status register query, is defined in "IEEE Std 488.2-1992", 10.12.

***IDN?** The *IDN?, identification query, is defined in "IEEE Std 488.2-1992", 10.14. *IDN? is used to retrieve information about the test set in ASCII format.

GPiB Syntax for the E1961A

***IDN?**, returns ASCII codes 32 through 126 excluding comma and semicolon in four comma separated fields. Field 1 returns the manufacturer, field 2 returns the instrument model number, field 3 returns the serial number, field 4 returns 0.

***OPC** The ***OPC**, operation complete command, is defined in "IEEE 488.2-1992", 10.18. ***OPC** causes the test set to continuously sense the No Operation Pending flag. When the No Operation Pending flag becomes TRUE, the OPC event bit in the standard event status register (ESR) is set to indicate that the state of all pending operations is completed. The ***OPC** common command is not recommended for use as an overlapped command.

***OPC?** The ***OPC?**, operation complete query, is defined in "IEEE Std 488.2-1992", 10.19. The ***OPC?** query allows synchronization between the controller and the test set using either the message available (MAV) bit in the status byte, or a read of the output OPC?. The ***OPC?** query does not effect the OPC event bit in the Standard Event Status Register (ESR). The ***OPC?** common command is not recommended for use as an overlapped command.

***OPT?** The ***OPT?**, option identification query, is defined in "IEEE Std 488.2-1992", 10.20. Each option will have a unique name, that name will be returned with the query.

***RST** The ***RST**, full preset command, is defined in "IEEE Std 488.2-1992", 10.32. ***RST** is the recommended command when performing a full preset on the test set. A ***RST** restores the majority of settings to their default values.

- ***RST** sets trigger arm to single
- **PRESet2** sets trigger arm to continuous

***SRE** The ***SRE**, service request enable command, is defined in "IEEE Std 488.2-1992", 10.34. The parameter range for this command is 0 through 255.

***SRE?** The ***SRE?**, service request enable query, is defined in "IEEE Std 488.2-1992", 10.35. Values returned by this query range from 0 through 255.

***STB?** The ***STB?**, read status byte query, is defined in "IEEE Std 488.2-1992", 10.36. Values returned by this query range from 0 through 255.

***WAI** The ***WAI**, wait-to-continue command, is defined in "IEEE Std 488.2-1992", 10.39. The ***WAI** command prevents the test set from executing any further commands or queries until all pending operation flags are false. The ***WAI** common command is not recommended for use as an overlapped command.

GPIB Syntax for the E1961A

Index

To find a syntax equivalent for a field on the Test Set's display.

1. Find the field name on the Test Set's display.
2. Look up the name in the alphabetical listing.
3. Turn to the page indicated.

Numerics

100 Hz BW BPF Center Frequency, 44
audio analyzer, 39
1st Alternate, 21
2nd Alternate, 21

A

ACC (control channel type), 10
ACC Channel, 10
ACP
 See also Adjacent Channel Power
Active Cell, 16
Active Cell Status, 10
Adjacent Channel Power
 1st Alternate (Lower, Upper), 21
 2nd Alternate (Lower, Upper), 21
Adjacent (Lower, Upper), 21
 average, 35
Adjacent Channel Power Setup
 Measurement Timeout, 38
 Multi-Measurement Count, 38
 Trigger Arm, 38
 Trigger Delay, 38
 Trigger Source, 38
Amplitude, 8
Amplitude Offset RF In/Out Port, 71
Analog MS TX Level (AVC setup info), 19
Analog MS TX Level (current AVC info), 20
Analog Transmit Power
 average, 35
 integrity, 24
 intermediate count, 24
 Minimum, Maximum, Average, Std Dev, 24
Analog Transmit Power Setup
 Measurement Timeout, 40

Multi-Measurement Count, 40
Trigger Arm, 40
Anl MS TX Level, 13
Application Selection, 69
Application Setup, 69
Application Switch, 69
Application, Revision, License, 69
ATXP
 See also Analog Transmit Power
Audio Analyzer
 Audio Frequency, 22
 Audio Level, 23
 Distortion, 22
 integrity, 22
 intermediate count, 22
 SINAD, 23
Audio Analyzer Setup
 100 Hz BW BPF Center Frequency, 39
De-Emphasis State, 39
Detector Type, 39
Expander Reference Level, 39
Filter Type, 39
Measurement Timeout, 39
Multi-Measurement Count, 39
SINAD/Distortion Fundamental Frequency, 39
SINAD/Distortion State, 39
Trigger Arm, 39
Audio Frequency, 22
Audio Generator, 8
Audio Level, 23
 average, 35
AVC (traffic channel type), 20
AVC Channel, 18
AVC Channel (current AVC info), 20
AVC Setup Info
 Analog MS TX Level, 19
 AVC Channel, 18
 SAT Color Code, 18
AVC Test, 16

B

Band Pass Filter Frequency
 FM, 39, 44
Beeper State, 69
Bit Error Count, 28, 35
Bit Error Ratio, 28, 35

C

Cal. first IQ mod, 8
Cal. second IQ mod, 8
Cell Power, 17
Cell Power (CW parameters), 17
Cell Power State (CW parameters), 17

Cellular (DCCH band), 11
Cellular (DTC band), 18
Control Ch Type
 ACC, 10
 DCCH, 10
Coupling, 8
Current AVC Info
 Analog MS TX Level, 20
 AVC Channel, 20
 SAT Color Code, 20
Current DTC Info
 Digital MS TX Level, 20
 DTC Band, 20
 DTC Channel, 20
 DTC Vocoder Type, 20
Current Traffic Channel Type, 20
CW, 16
CW Parameters
 Cell Power, 17
 Cell Power State, 17
 RF Generator Frequency, 17

D

DCCH (control channel type), 10
DCCH Band
 Cellular, 11
 PCS, 11
DCCH Channel, 11
debug feature, 6
Debug State, 70
De-Emphasis State
 audio analyzer, 39
 FM, 43
Default Gateway, 70
Detector Type
 Peak -, 43
 Peak (audio analyzer), 39
 Peak +, 43
 RMS (audio analyzer), 39
 RMS (FM), 43
Dig MS TX Level, 13
Digital MS Protocol Version
 (mobile station information), 15
Digital MS TX Level (current DTC info), 20
Digital MS TX Level (DTC setup info), 19
Digital Transmit Power
 average, 35
Digital Transmit Power Setup
 Measurement Timeout, 42
 Multi-Measurement Count, 42
 Trigger Arm, 42
 Trigger Delay, 42
 Trigger Source, 42
Disable MAHO Reporting, 13

Index

- Distortion
 - audio, 22
 - audio (average), 35
 - FM, 26
 - FM (average), 35
- Distortion (%)
 - Minimum, Maximum, Average, 26
- Distortion Fundamental
 - Frequency, 43
- Distortion State, 43
- DTC (traffic channel type), 20
- DTC Band
 - Cellular, 18
 - PCS, 18
- DTC Band (current DTC info), 20
- DTC Burst Size
 - Normal, 11
 - Shortened, 11
- DTC Channel, 18
- DTC Channel (current DTC info), 20
- DTC Induced Err, 12
- DTC Setup Info
 - Digital MS TX Level, 19
- DTC Test, 16
- DTC Vocoder Type
 - ACELP(CC1), 18
 - VSELP, 18
- DTC Vocoder Type (current DTC info), 20
- DTXP
 - See also* Digital Transmit Power
- E**
- Enable MAHO Reporting, 13
- End Call, 12
- ESN (Decimal) (mobile station information), 13
- ESN (Hex) (mobile station information), 13
- EVM
 - See Also* RMS EVM
- EVM1
 - maximum, 35
- EVM10
 - maximum, 35
- EVM10 Measurement, 47, 49
- Execute Handoff, 13
- Expander Reference Level
 - audio analyzer, 39
- Expander State, 43
- Expected CW Power (receiver control), 36
- Expected Power Control (receiver control), 36
- Ext FM State, 12
- F**
- Filter Type
 - 100 Hz BW BPF (audio analyzer), 39
 - 100 Hz BW BPF (FM), 44
 - 300 Hz to 15 kHz (audio analyzer), 39
 - 300 to 15 k (FM), 44
 - 50 Hz to 15 kHz (audio analyzer), 39
 - 50 to 15 k (FM), 44
 - C-Message (audio analyzer), 39
 - C-Message (FM), 44
 - None (audio analyzer), 39
 - None (FM), 44
- FM Dev (kHz) RMS
 - Minimum, Maximum, Average, 25
- FM Deviation, 25
 - average, 35
- Freq Error (Hz)
 - Minimum, Maximum, Average, 27, 29
- Frequency, 8
 - frequency stability, 27
 - frequency stability (average), 35
- Frequency (kHz)
 - Minimum, Maximum, Average, 27
- Frequency Error, 27
 - modulation accuracy, 29
- Frequency Modulation
 - Distortion, 26
 - FM Deviation, 25
 - integrity, 26
 - intermediate count, 26
 - Modulation Frequency, 26
- Frequency Modulation Setup
 - 100 Hz BW BPF Center Frequency, 44
 - De-Emphasis State, 43
 - Detector Type, 43
 - Distortion Fundamental
 - Frequency, 43
 - Distortion State, 43
 - Expander State, 43
 - Filter Type, 44
 - Measurement Timeout, 44
 - Multi-Measurement Count, 43
 - Trigger Arm, 43
- Frequency Stability
 - Frequency, 27
 - Frequency Error, 27
 - integrity, 27
 - intermediate count, 27
 - Worst Frequency Error, 27
- Frequency Stability Setup
 - Measurement Timeout, 45
 - Multi-Measurement Count, 45
 - Trigger Arm, 45
- G**
- GPIO Address, 70
- I**
- Instrument Information
 - Last Calibration, 8
 - Test Application, 71
- Instrument Setup
 - Beeper State, 69
 - Default Gateway, 70
 - GPIO Address, 70
 - LAN IP Address, 70
 - Subnet Mask, 70
- Int FM Dev, 12
- Int FM Freq, 12
- integrity
 - analog transmit power, 24
 - audio measurements, 22
 - FM, 26
 - frequency stability, 27
 - intermediate count
 - analog transmit power, 24
 - audio measurements, 22
 - FM, 26
 - frequency stability, 27
- IQ Tuning
 - FETCh, 28
- L**
- LAN IP Address, 70
- Last Calibration, 8
- Loopback BER
 - Bit Error Count, 28
 - Bit Error Ratio, 28
 - bits tested, 35
- Loopback BER Setup
 - Measurement Timeout, 48
 - Number of bits to test, 48
 - Trigger Arm, 48
- M**
- MACC
 - See also* Modulation Accuracy
- Magnitude Error
 - maximum, 35
 - See Also* RMS Magnitude Error
- MAHO BER, 13
- MAHO Info, 13
- MAHO Reported Information, 13
- MAHO RSSI, 13
- Manual Analog Power Cellular
 - Band (receiver control), 36

Index

- Manual Digital Power Cellular Band (receiver control), 36
- Manual Digital Power PCS Band (receiver control), 36
- MCC, 13
- Measurement Frequency
 - Auto (receiver control), 36
 - manual (receiver control), 37
- Measurement Timeout
 - adjacent channel power, 38
 - analog transmit power, 40
 - audio analyzer, 39
 - digital transmit power, 42
 - FM, 44
 - frequency stability, 45
 - Loopback BER, 48
 - modulation accuracy, 47, 49
- Message Log, 72
- Min 1 (Hex) (mobile station information), 15
- Min 2 (Hex) (mobile station information), 15
- Mobile Station Information
 - Digital MS Protocol Version, 13
 - ESN (Decimal), 13
 - ESN (Hex), 13
 - Min 1 (Hex), 15
 - Min 2 (Hex), 15
 - MS Called Party Number, 15
 - Phone Number, 15
 - Rate Capability, 15
 - SCM, 15
- Modulation Accuracy
 - Frequency Error, 29
 - Origin Offset, 31
 - RMS EVM1, 29
 - RMS EVM10, 29
 - RMS Magnitude Error, 29
 - RMS Phase Error, 31
- Modulation Accuracy Setup
 - EVM10 Measurement, 47, 49
 - Measurement Timeout, 47, 49
 - Multi-Measurement Count, 46, 49
 - Trigger Arm, 46, 49
 - Trigger Delay, 47, 49
 - Trigger Source, 47, 49
- Modulation Frequency, 26
- MS Called Party Number (mobile station information), 15
- MS TX Level, 19
- Multi-Measurement Count
 - adjacent channel power, 38
 - analog transmit power, 40
 - audio analyzer, 39
 - digital transmit power, 42
 - FM, 43
 - frequency stability, 45
 - modulation accuracy, 46, 49
- N**
 - Normal (DTC burst size), 11
 - Number of bits to test
 - Loopback BER, 48
- O**
 - Operating Mode
 - Active Cell, 16
 - AVC Test, 16
 - CW, 16
 - DTC Test, 16
 - Origin Offset
 - maximum, 35
 - modulation accuracy, 31
 - Origin Offset (dBc)
 - Minimum, Maximum, Average, 31
 - Originate Call, 16
- P**
 - Paging Number, 16, 17
 - PCS (DCCH band), 11
 - PCS (DTC band), 18
 - Phase Error
 - maximum, 35
 - See Also* RMS Phase Error
 - Phone Number (mobile station information), 15
 - Port Configuration
 - Amplitude Offset (RF In/Out port), 71
 - programming, debug feature, 6
 - Pulse, 8
- R**
 - Rate Capability (mobile station information), 15
 - Receiver Control
 - Expected CW Power, 36
 - Expected Power Control, 36
 - Manual Analog Power Cellular Band, 36
 - Manual Digital Power Cellular Band, 36
 - Manual Digital Power PCS Band, 36
 - Measurement Frequency
 - Auto, 36
 - manual, 37
 - Uplink Frequency
 - Auto, 36
 - manual, 37
 - Rev. License, 69
 - RF Gen Freq, 17
 - RF Gen Freq Ctrl, 11
 - RF Generator Frequency (CW parameters), 17
 - RMS EVM1
 - modulation accuracy, 29
 - RMS EVM1 (%)
 - Minimum, Maximum, Average, 29
 - RMS EVM10
 - modulation accuracy, 29
 - RMS EVM10 (%)
 - Minimum, Maximum, Average, 29
 - RMS Mag Error (%)
 - Minimum, Maximum, Average, 29
 - RMS Magnitude Error
 - modulation accuracy, 29
 - RMS Phase Error (degrees)
 - Minimum, Maximum, Average, 31
 - RMSPhase Error
 - modulation accuracy, 31
 - S**
 - SAT Color Code, 18
 - SAT Color Code (current AVC info), 20
 - SAT State, 10
 - SCM (mobile station information), 15
 - Shortened (DTC burst size), 11
 - SINAD, 23
 - average, 35
 - SINAD/Distortion Fundamental Frequency, 39
 - audio analyzer, 39
 - SINAD/Distortion State, 39
 - audio analyzer, 39
 - SOC, 20
 - Subnet Mask, 70
 - System ID, 20
 - T**
 - Test Application (instrument information), 71
 - Traffic Ch Type
 - AVC, 20
 - DTC, 20
 - Trigger Arm
 - adjacent channel power, 38
 - analog transmit power, 40
 - audio analyzer, 39
 - digital transmit power, 42
 - FM, 43
 - frequency stability, 45

Index

- Loopback BER, 48
- modulation accuracy, 46, 49
- Trigger Delay
 - adjacent channel power, 38
 - digital transmit power, 42
 - IQ Tuning, 47
 - MACC, 49
- Trigger Source
 - adjacent channel power, 38
 - digital transmit power, 42
 - IQ Tuning, 47
 - MACC, 49
- U**
- Uplink Frequency
 - Auto (receiver control), 36
 - manual (receiver control), 37
- V**
- Vocoder Type
 - ACELP(CC1), 18
 - VSELP, 18
- W**
- Worst Frequency Error, 27, 35